

Installation & Maintenance Instructions

BR385



Supplied by

247cable.com

Call us on +44 (0)118 916 9420 | Email info@247able.com



Installation & Maintenance Instructions

BR385

Intrinsically safe sounder

BEKA
associates

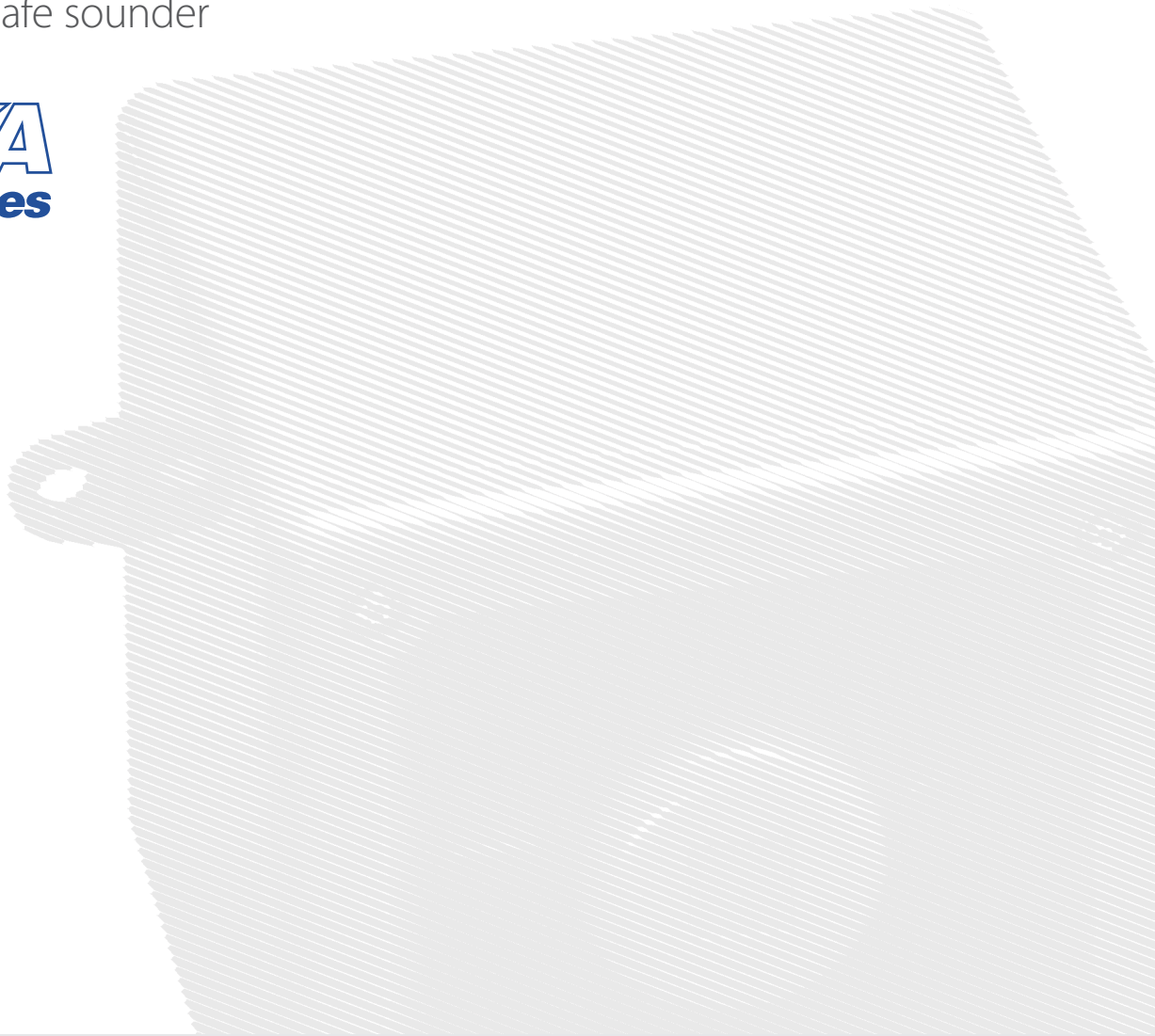

Reading Office

Cutbush Park, Danehill, Lower Earley,
Reading, Berkshire. RG6 4UT. UK.
Tel: +44 (0)118 9311188
Email: info@able.co.uk

Aberdeen Office

Unit 6 Airside Business Park, Kirkhill Industrial Estate,
Dyce, Aberdeen. AB21 0GT. UK.
Tel: +44 (0)1224 725999
Email: ab@able.co.uk

Internet: www.able.co.uk
e-procurement: www.247able.com
Registered in England No: 01851002
VAT No: GB 417 2481 61



Instruction sheet for BR385 Intrinsically safe Sounder

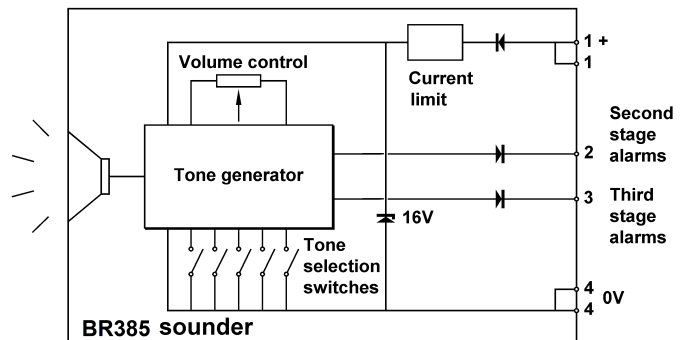
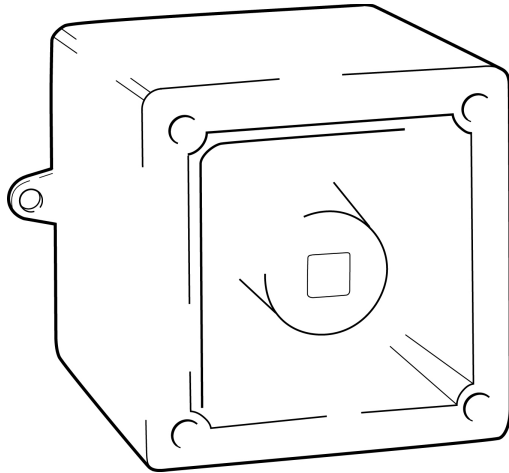

Fig 1 Simplified block diagram

BR385 sounders are CE marked to show compliance with the European Explosive Atmospheres Directive 94/9/EC and the European EMC Directive 2004/108/EC

1. INTRODUCTION

The BR385 is a third generation ATEX & FM certified intrinsically safe sounder that produces a loud warning signal in a hazardous area. Forty nine different first stage alarm sounds can be selected by internal switches and each one can be externally changed to a second or third stage alarm sound. For ATEX installations the sounder can be used in all gas groups and may be powered from a BA386 LED flashing beacon, allowing a combined audible and visual alarm to be constructed.

FM Approval, which is described in Appendix 1 of these instructions, does not permit use with the BA386 LED flashing beacon.

2. DESCRIPTION

Fig 1 shows a simplified block diagram of a BR385 sounder. The device operates immediately power is applied to the + and - terminals which are duplicated to allow a second sounder to be connected in parallel, or for an end of line monitoring resistor to be installed. The output tone is defined by the position of the six internal switches and this tone can be changed to a second or third stage alarm tone by connecting terminals S2 or S3 to the - terminal of the sounder. The tone generator is crystal controlled to ensure that when two sounders are started at the same time their output tones remain synchronised.

3. SUPPLY VOLTAGE

For hazardous area installations, BR385 sounders must be powered from a certified Zener barrier or galvanic isolator that will supply between 8 and 28V at the + and - terminals of the sounder.

Sounders may be tested or used in safe areas without a Zener barrier or galvanic isolator, but at supply voltages above 16V the internal current limit will function and the audio output will be reduced. Direct connection to supplies up to 28V of either polarity will not damage the sounder, but it is recommended that sounders are not operated continuously with a direct supply greater than 16V.

4. ATEX INTRINSIC SAFETY CERTIFICATION

4.1 ATEX certificate

The BR385 sounder has been issued with an EC-Type Examination Certificate Sira06ATEX2032X by Notified Body Sira Certification Service. This has been used to confirm compliance with the European ATEX Directive 94/9/EC for Group II, Category 1G equipment at the time of certification. See product Declaration of Conformity for confirmation of compliance with current harmonised standards.

The sounder carries the Community Mark and subject to local codes of practice, may be installed in any of the EEA member countries. This instruction sheet describes installations which conform to BS EN60079:Part 14 Electrical Installation in Hazardous Areas. When designing systems for installation outside the UK, the local Code of Practice should be consulted.

 II 1G Ex ia IIC T4 Ga (-40°C ≤ Ta ≤ +60°C)

The SIRA EC-Type Examination Certificate defines the following eight requirements plus special conditions for safe use. Practical implications are explained in later sections of this instruction sheet.

- 1) The certification marking is as follows:

BR385 Sounder

 II 1G Ex ia IIC T4 Ga (-40°C ≤ Ta ≤ +60°C)
SIRA 06ATEX2032X

 0359 IS Class I, Zone 0, AEx ia IIC T4
IS Class I, Division 1, Groups A,B,C,D
Control Drawing No. CI385-32

 APPROVED Term.+ w.r.t. Term. - Ui=28V Ii=93mA
P=660mW Ci=0 Li=0
Term. S2&S3 w.r.t. Term. - Ui=28V Ii=0mA

WARNINGS : Year / Serial No.

To avoid a possible electrostatic charge only clean with a damp cloth

To prevent ignition of flammable or combustible atmospheres, disconnect power before servicing.
Substitution of components may impair safety.

BEKA associates
Hitchin, Hertfordshire,
England. www.beka.co.uk

- 2) The equipment may be used in Zones 0, 1 and 2 with flammable gases and vapours with apparatus groups IIA, IIB & IIC and with temperature classes T1, T2, T3 and T4.
- 3) The equipment is only certified for use in ambient temperatures in the range -40°C to +60°C and should not be used outside this range.

- 4) The certificate number has an 'X' suffix, which indicates that the certificate contains one of more special conditions for safe use. Those installing or inspecting the equipment should refer to this section of the certificate.
- 5) The equipment has not been assessed as a safety-related device (as referred to by Directive 94/9/EC Annex II, clause 1.5).
- 6) Installation of this equipment shall be carried out by suitably trained personnel in accordance with the applicable code of practice.
- 7) Repair of this equipment shall only be carried out by the manufacturer or in accordance with the applicable code of practice.
- 8) The certification of this equipment relies on the following materials used in its construction:

Enclosure: ABS Plastic

If the equipment is likely to come into contact with aggressive substances, then it is the responsibility of the user to take suitable precautions that prevent it from being adversely affected, thus ensuring that the type of protection is not compromised.

"Aggressive substances" - e.g. acidic liquids or gases that may attack metals, or solvents that may affect polymeric materials.

"Suitable precautions" - e.g. regular checks as part of routine inspections or establishing from the material's data sheet that it is resistant to specific chemicals.

SPECIAL CONDITIONS FOR SAFE USE

The equipment has an ingress protection rating of IP66. However, if it has been supplied without cable entry devices, then the user shall ensure that the devices that are fitted will provide an ingress protection that is appropriate to the environment in which it is installed i.e. IP20 or better.

The total capacitance connected to terminals + wrt - (i.e. the capacitance of the cable plus any other capacitance) shall not exceed 83nF.

The equipment shall not be directly installed in any process where its enclosure might be electro-statically charged by the rapid flow of a non-conductive media.

The equipment shall only be supplied via Terminals + w.r.t. Terminals - from a barrier having a maximum open circuit voltage U_0 that is $\leq 28V$ and a maximum short circuit current I_0 that is $\leq 93mA$, where I_0 is resistively limited. The barrier or galvanic isolator shall be ATEX certified by a notified body.

4.2 Zones, Gas Groups and T rating

The BR385 sounder has been certified Ex ia IIC T4 Ga. When connected to approved Zener barriers or galvanic isolators it may be installed in:

- | | |
|--------|---|
| Zone 0 | explosive gas air mixture continuously present. |
| Zone 1 | explosive gas air mixture likely to occur in normal operation. |
| Zone 2 | explosive gas air mixture not likely to occur, and if it does, it will only exist for a short time. |

Warning Do not install the BR385 where it may accumulate an electrostatic charge from a rapid flow of dry air.

Be used with gases in groups:

- | | |
|---------|----------|
| Group A | propane |
| Group B | ethylene |
| Group C | hydrogen |

Having a temperature classification of:

- | | |
|----|-------|
| T1 | 450°C |
| T2 | 300°C |
| T3 | 200°C |
| T4 | 135°C |

4.3 Terminals + and -

Power is supplied to the sounder via terminals + & - which have the following maximum input safety parameters:

U_i	=	28V
I_i	=	93mA dc
P_i	=	0.66W

BR385 sounders may be powered from any ATEX Ex ia IIC certified Zener barrier or galvanic isolator having output parameters equal to, or less than, these limits. e.g. a certified 28V, 93mA, 0.66W Zener barrier or isolator may be used.

The BR385 ATEX certificate specifies that the maximum permitted total capacitance that may be connected between the + and - terminals shall not exceed 83nF, irrespective of the Zener barrier or galvanic isolator powering the sounder. This total capacitance includes the cable capacitance plus the capacitance of any other connected device. This should not be restrictive unless the sounder and the barrier or isolator are a long way apart. Single pair instrumentation cables have a typical capacitance of 100pF/metre rising to 350pF/metre for multicore cables and are unlikely to exceed 600pF/metre allowing a cable length of up to 830, 230 or 138 metres respectively.

Up to three BR385 sounders may be connected in parallel and powered from a common barrier or isolator providing the voltage between the + and - terminals does not fall below 8V. Connecting two sounders in parallel will reduce the output from each sounder by about 3dB. Three sounders should only be powered from a common supply when the maximum supply voltage is available.

4.4 Terminals S2 and S3

When terminals S2 or S3 are connected to 0V (- terminal) the sounder output tone changes to the second or third stage alarm respectively. The input safety parameters for these terminals are:

U_i	=	28V
I_i	=	0mA

Therefore for control from the safe area terminals S2 & S3 may only be connected to a certified diode return barrier, or the contacts of a certified intrinsically safe relay. For functional reasons diode return barriers with a voltage drop of less than 0.9V must be used. The maximum permitted cable capacitance C_0 will be specified on the diode return barrier ATEX certificate, but again should not be restrictive.

For control from the hazardous area terminals S2 & S3 may be directly connected to a mechanically operated switch in the hazardous area complying with the requirements for simple apparatus as defined in EN 60079-11. i.e. having IP20 protection and able to withstand a 500V rms insulation test to earth for one minute.

5. INSTALLATION

BR385 sounders should only be installed by trained competent personnel.

5.1 Mounting

The BR385 sounder may be secured to any flat surface using the two 7mm diameter fixing holes. The enclosure provides IP66 protection and is suitable for installation in sheltered exterior locations providing it is positioned so that water can not collect in the horn, and the cable entry is sealed.

5.2 Installation procedure

- Secure the BR385 sounder to a flat surface via the two 7mm dia fixing holes in the mounting feet.
- Remove the front of the sounder by unscrewing the four captive corner screws and pulling the front away from the enclosure.
- Fit an appropriate 20mm cable gland or conduit entry into the untapped hole in the enclosure and connect the field wiring to the appropriate sounder terminals as shown in Fig 3. The power supply terminals + and - are duplicated so that sounders may be connected in parallel, or an end-of-line monitoring resistor may be fitted.
- Select the required output tone by positioning the six switches as shown in Table 1 and Fig 3.
- Apply power to the sounder and adjust the internal volume control to provide the required sound level.
- Replace the front of the sounder and tighten the four corner screws.

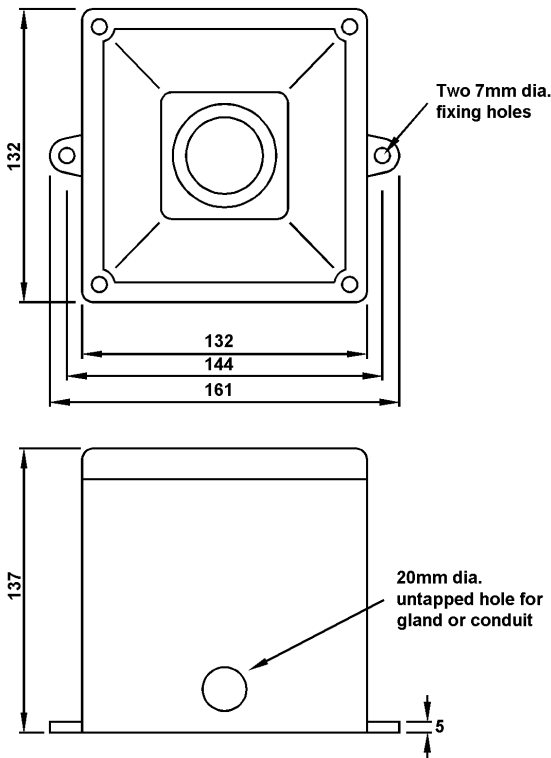

Fig 2 Enclosure

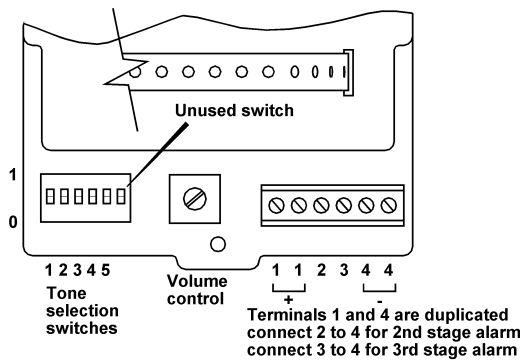

Fig 3 Location of field terminals and controls.

WARNING
To avoid a possible electrostatic charge only clean BR385 sounder with a damp cloth

6. ELECTRICAL SYSTEM DESIGN FOR INSTALLATION IN HAZARDOUS AREAS USING ZENER BARRIERS

6.1 Single stage alarm

If the control switch is in the positive supply, or the power supply is being turned on and off, only a single channel Zener barrier is required as shown in Fig 4. This circuit may also be used if the sounder is being controlled from the hazardous area by a mechanically activated switch complying with the requirements for simple apparatus, as defined by EN 60079-11. i.e. having IP20 protection and able to withstand a 500V rms insulation test to earth for one minute.

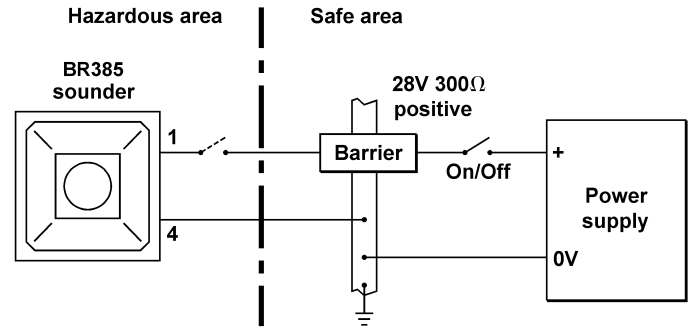

Fig 4 Single stage alarm using single channel barrier.

If the negative side of the power supply and one side of the control switch are earthed, the circuit shown in Fig 5 may be used.

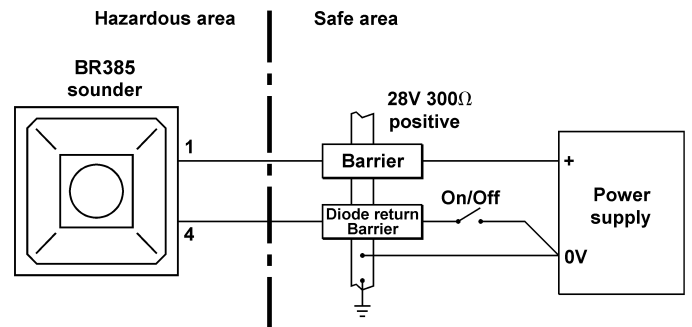

Fig 5 Single stage alarm using two channel barrier.

6.2 Multi-stage alarm

Connecting terminal S2 to 0Vv activates the second stage alarm, and similarly terminal 3 for the third stage alarm. Fig 6 shows how diode return barrier(s) may be used to control the sounder from the safe area. If only two stages of alarm are required the third stage barrier should be omitted, the 28V 93mA barrier and the single diode return channel may then be contained in one package.

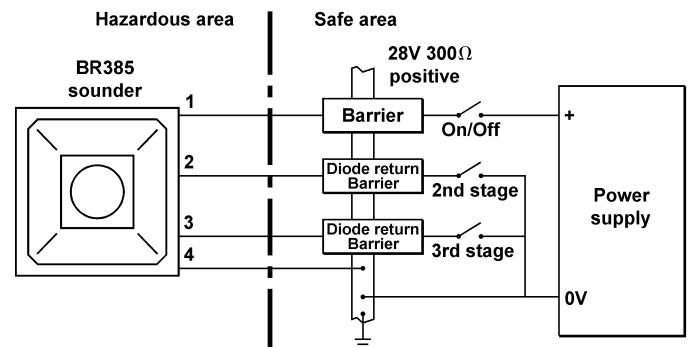

Fig 6 Multi-stage alarm using Zener barriers.

7. ELECTRICAL SYSTEM DESIGN FOR INSTALLATION IN HAZARDOUS AREAS USING GALVANIC ISOLATORS.

Galvanic isolators although more expensive than Zener barriers, do not require a high integrity earth connection. For small systems where a high integrity earth is not already available, the use of galvanic isolators often reduces the overall installation cost and simplifies design.

7.1 Single stage alarm

BR385 sounders may be powered by any Ex ia ATEX certified galvanic isolator having output parameters within the limits specified in section 4.3. The sounder may be controlled by turning the galvanic isolator on and off, or from the hazardous area by a mechanically activated switch complying with the requirements for simple apparatus as defined by EN 60079-11. i.e. having IP20 protection and able to withstand a 500V rms insulation test to earth for one minute.

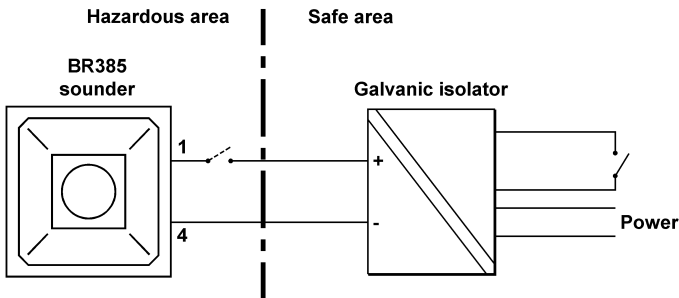

Fig 7 Single stage alarm using galvanic isolator.

7.2 Multi-stage alarm

Fig 8 shows a typical application in which the first and second stage alarm tones are activated by the alarm outputs of a BA327E intrinsically safe loop powered indicator. The BA327E alarm outputs have been certified as simple apparatus and may therefore be used to switch the BR385 sounder in the hazardous area. The contacts of most certified intrinsically safe relays may also be used in the same way.

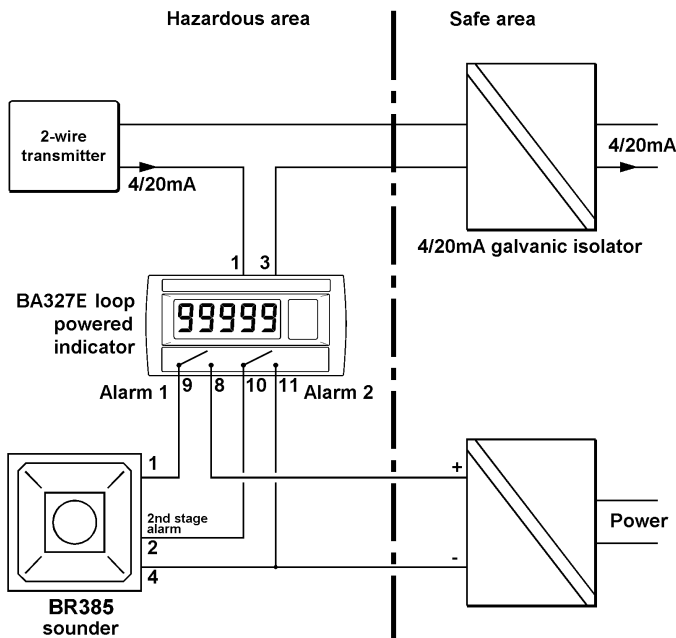

Fig 8 Loop-powered BA327E intrinsically safe indicator activating BR385 first and second stage alarms

8. ACCESSORIES

8.1 Tag number

BR385 sounders can be supplied identified by a tag number thermally printed on a self adhesive label.

9. SERVICING

No attempt should be made to repair a faulty BR385 sounder. Suspect sounders should be returned to BEKA associates or our local agent for repair.

10. GUARANTEE

Sounders which fail within the guarantee period should be returned to BEKA associates or our local agent. It is helpful if a brief description of the fault symptoms is provided.

11. CUSTOMER COMMENTS

BEKA associates is always pleased to receive comments from customers about our products and services. All communications are acknowledged and whenever possible, suggestions are implemented.

Tone Number		Switch Settings	Second Stage Alarm	Third Stage alarm
		1 2 3 4 5 6		
Tone 1	Continuous 340Hz	0 0 0 0 0	Tone 2	Tone 5
Tone 2	Alternating 800/1000Hz @ 0.25s intervals	1 0 0 0 0	Tone 17	Tone 5
Tone 3	Slow whoop 500/1200Hz @ 0.3Hz with 0.5s gap repeated	0 1 0 0 0	Tone 2	Tone 5
Tone 4	Sweeping 500/1000Hz @ 1Hz	1 1 0 0 0	Tone 6	Tone 5
Tone 5	Continuous 2400Hz	0 0 1 0 0	Tone 3	Tone 20
Tone 6	Sweeping 2400/2900Hz @ 7Hz	1 0 1 0 0	Tone 7	Tone 5
Tone 7	Sweeping 2400/2900Hz @ 1Hz	0 1 1 0 0	Tone 10	Tone 5
Tone 8	Siren 500/1200/500Hz @ 0.3Hz	1 1 1 0 0	Tone 2	Tone 5
Tone 9	Sawtooth 1200/500Hz @ 1Hz - <i>D.I.N.</i>	0 0 0 1 0	Tone 15	Tone 2
Tone 10	Alternating 2400/2900Hz @ 2Hz	1 0 0 1 0	Tone 7	Tone 5
Tone 11	Intermittent 1000Hz @ 1Hz	0 1 0 1 0	Tone 2	Tone 5
Tone 12	Alternating 800/1000Hz @ 0.875Hz	1 1 0 1 0	Tone 4	Tone 5
Tone 13	Intermittent 2400Hz @ 1Hz	0 0 1 1 0	Tone 15	Tone 5
Tone 14	Intermittent 800Hz 0.25s ON, 1s OFF	1 0 1 1 0	Tone 4	Tone 5
Tone 15	Continuous 800Hz	0 1 1 1 0	Tone 2	Tone 5
Tone 16	Intermittent 660Hz 150Ns ON, 150ms OFF	1 1 1 1 0	Tone 18	Tone 5
Tone 17	Alternating 544Hz (100ms) / 440Hz (400ms) – <i>NFS 32-001</i>	0 0 0 0 1	Tone 2	Tone 27
Tone 18	Intermittent 660Hz 1.8s ON, 1.8s OFF	1 0 0 0 1	Tone 2	Tone 5
Tone 19	Sweep 1400Hz to 1600Hz up 1s 1600Hz to 1400Hz down 0.5s	0 1 0 0 1	Tone 2	Tone 5
Tone 20	Continuous 660Hz	1 1 0 0 1	Tone 2	Tone 5
Tone 21	Alternating 554/440Hz @ 1Hz	0 0 1 0 1	Tone 2	Tone 5
Tone 22	Intermittent 544Hz @ 0.875Hz	1 0 1 0 1	Tone 2	Tone 5
Tone 23	Intermittent 800Hz @ 2Hz	0 1 1 0 1	Tone 6	Tone 5
Tone 24	Sweeping 800/1000Hz @ 50Hz	1 1 1 0 1	Tone 29	Tone 5
Tone 25	Sweeping 2400/2900Hz @ 50Hz	0 0 0 1 1	Tone 29	Tone 5
Tone 26	Simulated bell	1 0 0 1 1	Tone 2	Tone 15
Tone 27	Continuous 554Hz	0 1 0 1 1	Tone 26	Tone 5
Tone 28	Continuous 440Hz	1 1 0 1 1	Tone 2	Tone 5
Tone 29	Sweeping 800/1000Hz @ 7Hz	0 0 1 1 1	Tone 7	Tone 5
Tone 30	Continuous 300Hz	1 0 1 1 1	Tone 2	Tone 5
Tone 31	Sweeping 660/1200 @ 1Hz	0 1 1 1 1	Tone 26	Tone 5
Tone 32	Two Tone Chime	1 1 1 1 1	Tone 26	Tone 15
Tone 33	Intermittent 745Hz	0 0 0 0 1	Tone 2	Tone 5
Tone 34	Alternating 1000/2000Hz @ 0.5s – <i>Singapore</i>	1 0 0 0 1	Tone 38	Tone 45
Tone 35	420Hz @ 0.625s - <i>Australian Alert</i>	0 1 0 0 1	Tone 36	Tone 5
Tone 36	500-1200Hz 3.75s / 0.25s - <i>Australian Evacuate</i>	1 1 0 0 1	Tone 35	Tone 5
Tone 37	Continuous 1000Hz	0 0 1 0 1	Tone 9	Tone 45
Tone 38	Continuous 2000Hz	1 0 1 0 1	Tone 34	Tone 45
Tone 39	Intermittent 800Hz 0.25s ON 1s OFF	0 1 1 0 1	Tone 23	Tone 17
Tone 40	Alternating 544Hz (100ms) / 440Hz (400ms) – <i>NFS 32-001</i>	1 1 1 0 1	Tone 31	Tone 27
Tone 41	Motor Siren – Slow rise to 1200Hz	0 0 0 1 0	Tone 2	Tone 5
Tone 42	Motor Siren – Slow rise to 800Hz	1 0 0 1 0	Tone 2	Tone 5
Tone 43	Continuous 1200Hz	0 1 0 1 0	Tone 2	Tone 5
Tone 44	Motor Siren – Slow rise to 2400Hz	1 1 0 1 0	Tone 2	Tone 5
Tone 45	Intermittent 1000Hz 1s ON, 1s OFF	0 0 1 1 0	Tone 38	Tone 34
Tone 46	Sawtooth 1200/500Hz @ 1Hz - <i>D.I.N. (PFEER P.T.A.P)</i>	1 0 1 1 0	Tone 47	Tone 37
Tone 47	Intermittent 1000Hz 1s ON, 1s OFF – <i>PFEER General Alarm</i>	0 1 1 1 0	Tone 46	Tone 37
Tone 48	420Hz @ 0.625s - <i>Australian Alert</i>	1 1 1 1 0	Tone 49	Tone 5
Tone 49	500-1200Hz 3.75s / 0.25s - <i>Australian Evacuate</i>	0 0 0 1 1	Tone 26	Tone 37

Table 1 Function of tone selection switches

APPENDIX 1

Installation in USA

A1.0 Factory Mutual Approval

For installations in the USA the BR385 sounder has been approved by Factory Mutual as intrinsically safe for use in Divisions 1 and 2 with Class I gases.

BR385 installations must comply with the BEKA associates Control Drawing CI385-32, ANSI/ISA RP12.06.01 and the National Electrical Code ANSI/NFPA70.

Copies of the FM Control Drawings are available from BEKA associates Ltd and:

Exloc Instruments Inc
PO Box 861406
Warrenton
VA 20187
USA
Tel: 540 428 3088
Fax: 540 428 3028
e-mail: info@exloc.com

All the ATEX intrinsically safe circuits shown in these instructions may be used for installations in the USA, providing the Zener barriers or galvanic isolators are FM approved and the installation complies with the following:

A1.1 Classes, Divisions, Gas Groups and Temperature rating

The BR385 has been approved intrinsically safe by Factory Mutual for installation in:

Divisions 1 or 2
Zones 0, 1 or 2

For use with Class I gases in groups

A, B, C or D
IIC, IIB or IIA

Having a temperature classification of:

T1
T2
T3
T4

Note: The BR385 is not approved for use with Class II and III dusts and fibers.

A1.2 Terminals + and -

Power is supplied to the sounder via terminals + and – which have the following FM entity input parameters. The BR385 may therefore be powered from any FM Approved intrinsically safe source having output parameters equal to or less than:

U_o = 28V
I_o = 93mA
P_o = 0.66W

Terminals + and - have zero equivalent capacitance and inductance, i.e. C_i and L_i are zero. The maximum permissible total capacitance connected between the + and – terminals of the sounder i.e. the cable capacitance plus any other capacitance must not exceed 83nF. L_o of the Zener barrier or galvanic isolator powering the sounder defines the total allowable inductance.

A1.2 Terminals S2 and S3

When terminals S2 or S3 are connected to 0V (- terminal) the sounder output tone changes to the second or third stage alarm respectively. The input safety parameters for these terminals are:

U_i = 28V
I_i = 0mA

Therefore for control from the safe area terminals S2 & S3 may only be connected to a FM Approved diode return barrier, or to the contacts of an approved intrinsically safe relay. For functional reasons diode return barriers with a voltage drop of less than 0.9V must be used. The maximum permitted cable capacitance and inductance is equal to C_o and L_o of the Zener barrier or galvanic isolator connected to these terminals.