

Installation & Maintenance Instructions

MID-WEST INSTRUMENT

Model 105/106



Supplied by

247cable.com

Call us on +44 (0)118 916 9420 | Email info@247able.com

Installation and Operating Instructions - Model 105/106

1. Safety



Before installing verify compatibility to the process media and temperature in contact with the wetted parts. Incompatible media and / or operation at temperature extremes can cause premature degradation of materials which could result in safety risk to personnel.

Verify the selected pressure range (differential pressure and working pressure) and the switch ratings are within specification for your application.

Warning! *Remaining media may result in a risk to personnel, environment etc. Use sufficient precautionary measures when removing and transporting the product.*

1.1 Intended use: The indicating / non-indicating differential pressure switches are used for monitoring differential pressures in industrial applications. The manufacturer shall not be liable for any claims if the product is used in applications contrary to the intended use.

1.2 Personnel: Personnel installing and putting this instrumentation into service shall be suitably trained and qualified in accordance with local codes, practices and regulations.

PRODUCT DESCRIPTION

The Model 105/106 is a precision differential pressure instrument capable of working at low differential pressure in high pressure systems. The compact design results in a simple device that is reduced to essential and necessary elements with a high output motion and rugged construction.

The major components of the Model 105/106 are a two-piece body, a multiple diaphragm/bellows sensing element and over-pressure assembly, a torque tube assembly, a range spring and a gauge front assembly.

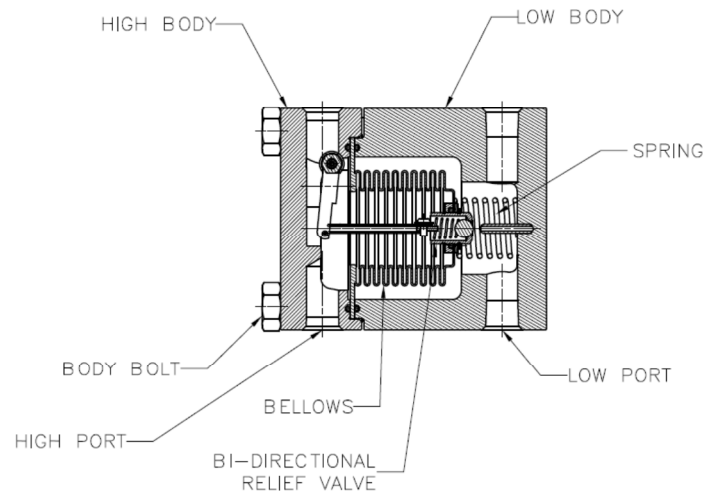

The body halves provide the pressure containment function. They also clamp the sensing element and over-pressure assembly between the body halves, isolating the high side and low side pressures of the system. The high side body half also provides a mount for the torque tube assembly.

The sensing element is exposed to and deflects in response to the differential pressure. This assembly incorporates a bi-directional relief valve which provides over-pressure protection in both directions. The opening of the valve in either direction equalizes the pressure and protects the unit.

A range spring is provided to adjust the spring rate of the system to suit the various differential pressure ranges of the instrument.

The torque tube assembly consists of a rigid shaft and torque tube. The torque tube is welded to a bushing which is fixed to the high side pressure body half. The other end of the tube is welded to the shaft. The shaft is connected to the sensing element by a linkage. As the sensing element deflects, it causes the torque tube to twist. The torque tube provides a frictionless leak-free transmission of an output which is proportional to the differential pressure.

The torque tube shaft extends into the gauge front assembly and is connected to a low-friction, **jeweled** movement which provides output to the pointer.

When equipped with switches, a contact is made or broken by the magnetic field of the internal magnet. See Bulletin ELECIM105/106 Series/latest for gauges with switches.

Installation and Operating Instructions - Model 105/106 Series

INSPECTION

Before installation check the product label on each instrument against the receiving paperwork and the intended application for correct part number, materials of construction, working pressure, dial range, etc. If equipped with switches, check electrical rating, type of enclosure, etc. Inspect for shipping damage and, if damaged, report it immediately.

NOTE - Before attempting repairs contact your local Mid-West Representative or our factory. Failure to do so will void any warranty.

INSTALLATION

Model 105/106 is calibrated and tested prior to shipment and is ready for immediate installation. Use of the following installation procedures should eliminate potential damage and provide optimum trouble-free operation.

1. CONNECTIONS

Dual ¼" FNPT connections, top and bottom, are provided as standard however check the paperwork for the connections ordered. They are identified as "HIGH" and "LOW" for high and low pressure. Be sure to plumb to proper connections on your system. The other two ports should either be plugged or plumbed as drains or bleeds, depending on whether the service is liquid or gas.

NOTE: It is strongly recommended that a 3-valve manifold be used in plumbing your model 105/106 to your system. Properly used it should insure that your instrument is not over-ranged or damaged by pressure shocks during pressurization. It will facilitate later zeroing, ranging and calibration checking. It is good practice to purge or flush the instrument loop prior to connecting the instrument.

2. INSTRUMENT LOCATION

On liquid service, the instrument should be mounted **below** the process connections to facilitate self bleeding. On gas service, it should be located **above** the process fluid. If the process contains particulates, a "pigtail" loop or drop leg (manometer "U-tube" configuration) in the tubing will minimize the possibility of it migrating into the instrument.

NOTE – On liquid applications, unequal liquid heads on high or low side will result in an inaccurate differential pressure indication.

3. PANEL MOUNTING

The Model 105/106 is designed for mounting through the **front** of the instrument panel and is normally provided with a panel mounting kit. The kit consists of (4) panel mounting studs and nuts.

Refer to the table in Figure 1 on the last page for panel mount diagrams, dimensions, and options.

4. PIPE MOUNTING

An optional pipe mounting kit is available for mounting the gauge to a 2" vertical or horizontal pipe. Refer to drawing below pipe mount diagrams and dimensions

INSTRUMENT INSTALLATION RECOMMENDATIONS

Rapid pressurization can cause severe damage to the sensing element in pressure instruments. Rapid pressure change (either increase or decrease) can be described as a change in pressure occurring fast enough to drive an instrument full scale in less than one second.

Most better quality instruments have over-range protection built-in but they are mechanical in design and cannot be relied upon to react in time to protect the instrument against a rapid change in pressure.

The simplest method to avoid this problem is by installation and proper use of a 3-valve manifold. Open the equalizer valve prior to opening one or both of the block valves to insure pressure is applied simultaneously to both sides of the sensing element.

If a 3-valve manifold is not used, protection can be provided by installation of Mid-West Model 150 snubbers to both sides of the instrument. This unit provides an infinitely adjustable choke valve and an excess flow ball check. The ball check is designed not to shut off completely but will restrict flow during sudden changes in pressure while bleeding pressure to the instrument, preventing sudden surges from being transmitted to the instrument.

Refer any questions regarding these recommended procedures to the local Mid-West representative in your area or our factory in Sterling Heights, Michigan, U.S.A.

Installation and Operating Instructions - Model 105/106 Series

TROUBLE SHOOTING

1. Gauge does not indicate differential

- Check for proper hook up, high to "HIGH" and low to "LOW"
- Make certain block valves are open and, if using a 3-valve manifold, that the equalizer (balance) valve is closed.
- If A & B check out correctly, loosen or disconnect the high pressure line to determine if there is pressure to the instrument.
- If there is pressure to the instrument, check to determine that there is differential across the unit being monitored. If so, contact the factory for assistance and/or an "RGA" (return goods authorization) number to return the instrument for repair or replacement.

2. Indicating pointer off zero. (With block valves closed, equalizer valve open, or no system differential.)

- Tap gauge **lightly**.
- Make certain block valves are closed and equalizer valve is open.
- If A & B do not correct the "off zero" condition, remove the bezel and lens assembly by removing the (4) bezel screws. Loosen **slightly** the "phillips head" screw, located in a slot in the dial in the lower left dial area at about "7:30". Rotate the dial until "zero" is under the pointer, by use of any pointed object inserted in one of the small notches at the top and bottom of the dial. Retighten the "phillips head" screw and reinstall the bezel and lens assembly.

RECALIBRATION AND/OR REPAIR

- If recalibration or repair is required, secure and "RGA" (return goods authorization) number from Mid-West Instrument and return the instrument to the factory.
- If (1) is not practical we recommend you discuss your problem with one of our customer service representatives and request a "technical service" manual. Please have both the model and serial numbers available before calling.

MODEL NO.	DIAL SIZE	DIAMETER C	LENGTH H	LENGTH J	LENGTH K	LENGTH L
		Inch (mm)	Inch (mm)	Inch (mm)	Inch (mm)	Inch (mm)
105	4-1/2 in.	6.21 (157.7)	3.98 (101.1)	3.75 (95.3)	3.75 (95.3)	5.73 (145.5)
	6 in.	8.18 (208.0)	3.98 (101.1)	3.75 (95.3)	3.75 (95.3)	5.79 (147.1)
106	4-1/2 in.	6.21 (157.7)	3.77 (95.7)	3.25 (82.5)	3.00 (76.2)	5.25 (133.4)
	6 in.	8.18 (208.0)	3.77 (95.7)	3.25 (82.5)	3.00 (76.2)	5.31 (134.9)

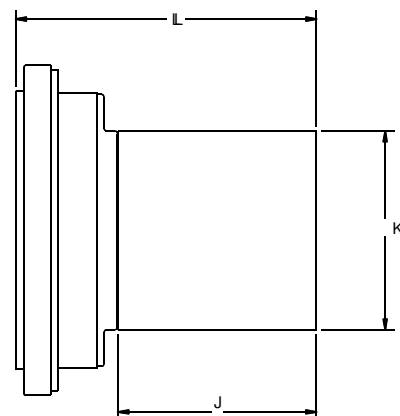
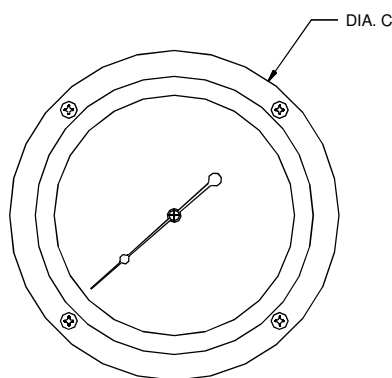
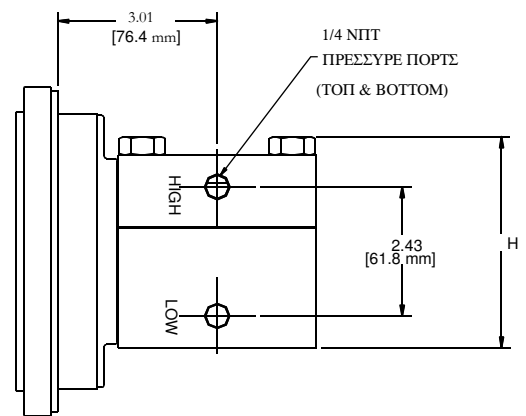

Installation & Maintenance Instructions

MID-WEST INSTRUMENT

Model 105/106 & 109 "Locked Logic"



Supplied by

247cable.com

Call us on +44 (0)118 916 9420 | Email info@247able.com

Mid-West[®] Instrument

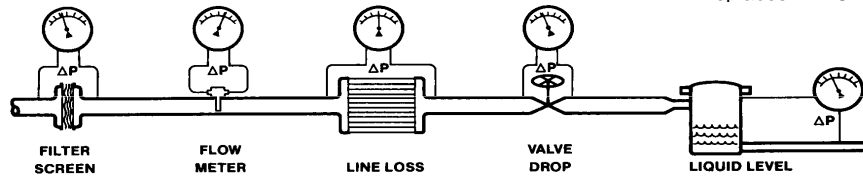

Model 105 /106 & 109 “Locked Logic” Installation and Operating Instructions

INSPECTION

Before installation carefully check the "Electrical Specifications" plate (See Fig. 1) on each instrument against the receiving paperwork and the intended application for the correct input and output. Make certain that the enclosure (NEMA 4 or NEMA 7) is appropriate for the area in which it is to be installed. Inspect for shipping damage and, if damaged, report it immediately. Verify when the unit is unpacked and in a vertical position that the pointer is on 0.

NOTE: BEFORE ATTEMPTING REPAIRS, CONTACT YOUR LOCAL MID-WEST REPRESENTATIVE OR OUR FACTORY. FAILURE TO DO SO WILL VOID ANY WARRANTY.



ELECTRICAL SPECIFICATIONS

INPUT: 8-28 VDC 115 VDC
115 VAC 50-60 HZ 230 VAC 50-60 HZ

OUTPUT (RESISTIVE LOAD):
10 A, 28 VDC
10 A, 115/240 VAC 50-60 HZ

FIG. 1: ELECTRICAL SPECIFICATION PLATE

PRODUCT DESCRIPTION

"Locked Logic" alarm control is a solid-state optical-electronic control available as an option on Mid-West Models 105/106 and 109 differential pressure gauges. The control is an optical "no-contact" design that does not affect the indicated accuracy of the instrument.

The standard unit is designed for an 8 to 28 VDC uninterruptable power input. Optional power inputs include 115 VDC, 115 VAC 50-60 hertz, or 230 VAC 50-60 hertz.

Output interface is via a set of (1) or (2) isolated SPDT or DPDT relay contacts, dependent on the number of set points specified. Interface to the relay contacts is customer configurable provided the relay contact ratings are not exceeded.

An alternate option allows the incorporation of an adjustable dead band. For this configuration the right set pointer determines the upper trigger point, while the left set pointer determines the lower trigger point. Output interface is to (1) isolated set of SPDT relay contacts.

INSTALLATION

All Mid-West "Locked Logic" alarm-controls are calibrated and tested prior to shipment and are ready for immediate installation.

1. **Panel Mounting** - Both weatherproof and explosion-proof models may be panel mounted. See Fig. 2 for panel cutout information.
 - A. **Weatherproof** - This unit mounts through the front of the panel. After making the panel cutout insert the (4) panel mounting studs, finger tight, into the (4) tapped holes in the rear of the housing. Insert the gauge through the panel, aligning the panel mounting studs with the holes in the panel. Install the (4) #8-32 nuts onto the studs and tighten securely.
 - B. **Explosion-proof** -

WARNING: THE COVER MUST NEVER BE REMOVED WHEN THERE IS POWER TO THE UNIT.

Normally pipe mounted, this unit may also be panel mounted through the front of the panel. Unless otherwise specified, your explosion-proof unit will be provided with a pipe mounting kit. To panel mount, remove the pipe mounting kit by removing the (4) hex headed 1/4 - 20 bolts attaching it to the back of the enclosure. Save the (4) bolts and washer for use in mounting to the panel. Refer to Fig. 2 for panel cutout information. Once the appropriate cutout is made, mount the unit through the front of the panel and install the (4) 1/4 - 20 bolts and washers from the back of the panel and into the enclosure. Tighten securely.

You may now proceed with plumbing and wiring the unit into your system.

2. **PIPE MOUNTING** - (See Fig. 2 for mounting instructions.)

WEATHERPROOF – Pipe mounting is an optional extra for Models 105, 106 & 109 "Locked Logic" units.

EXPLOSION-PROOF - A pipe mounting kit is provided as standard for all Model 105, 106 and 109 "Locked Logic" units unless otherwise specified.

3. **CONNECTIONS** - For plumbing the Model 105, 106 or 109 to the pressure connections on your system, follow the instructions for that instrument. Once accomplished, proceed with the electrical instructions that follow.

4. **ELECTRICAL** - Both weatherproof and explosion-proof "Locked Logic" enclosures have an opening, top rear, for a ½" or ¾" flexible cable or conduit connector. An appropriate connector must be installed before making connections to the wire leads provided. See the wiring interface drawing provided with your gauge for proper electrical connections to the gauge.

For Units supplied with both AC and DC input power leads, do not accidentally connect AC power to the DC leads. The unit will be damaged

CAUTION: FOLLOW ALL ELECTRICAL CODE REQUIREMENTS FOR VOLTAGE, AC OR DC SUPPLY AND ENVIRONMENTAL CONDITIONS AS REQUIRED LOCALLY.

NOTE: INSTALL THE FRONT COVER AND BEZEL ASSEMBLY AFTER SWITCH ADJUSTMENT, AND DO NOT LEAVE THE UNIT OUTDOORS WITHOUT A CONNECTOR IN THE ELECTRICAL OPENING OR THE UNIT MAY BE DAMAGED FROM ENVIRONMENTAL CONDITIONS.

5. **SETPOINT ADJUSTMENT** - Set pointers are adjustable from 5 to 95% of full scale and to within 5% (of full scale) of each other if equipped with (2) set pointers. The adjustment screws are inside the enclosure to protect against unauthorized adjustment. Before opening the unit to make a set point adjustment, check plant operating procedures and electrical codes. For weatherproof units, remove the (4) bezel screws and the bezel assembly. For explosion proof units, unscrew the window assembly from the housing.

CAUTION: BE SURE POWER IS TURNED OFF BEFORE REMOVING THE COVER FROM (EXPLOSION-PROOF) UNITS.

Insert a screwdriver in the setpoint adjustment slot and rotate until the setpointer is at the desired point on the scale. Replace the bezel assembly and screws, or window assembly.

6. **START UP** All "Locked Logic" set pointers, except adjustable dead-band units, have one green and one red state indication LED per set pointer assembly. Upon power up of the assembly the green LED(s) shall be lit and the output relay(s) de-energized. As the indicating pointer moves up scale and passes a set pointer, the green LED shall extinguish, the red LED shall be on, and the output relay shall energize. On declining differential the sequence shall be reversed.

For adjustable dead-band units, the left set pointer has 1 green and 1 red state indication LED. The right set pointer has no indicators. Upon power up of the assembly the green LED shall be lit and the output relay shall be de-energized. As the indicating pointer moves up scale and passes the Right set pointer, the green LED shall extinguish, the red LED shall be on, and the output relay shall energize. On declining differential (indicating pointer moves downscale), the red LED shall extinguish, the green LED shall be lit, and the relay shall de-energize when the indicating pointer passes the left set pointer.

Please note that these units use a reflective optical sensor that is sensitive to infrared light. Sunshine is a source of infrared. If the unit is placed outdoors, it is recommended, although not necessary, to either shade the unit or position the gauge so that the glass faces in either a East or West direction. In extremely rare cases the unit has triggered due to bright sunlight conditions. For this occurrence a tinted glass is available to correct this problem.

TROUBLE SHOOTING - SYMPTOM(S)

1. GAUGE DOES NOT INDICATE DIFFERENTIAL. Check trouble shooting procedures in the appropriate gauge manual and proceed accordingly.
2. L.E.D.'S DO NOT COME ON WHEN POWER IS TURNED ON. Check wiring diagram (Fig. 1) and wiring to make certain that all connections are properly and securely made. Also check to make certain that the proper power input is being provided.
3. UNIT "ALARMS" INADVERTENTLY. Check for sunshine condition described above. Make necessary adjustments and re-test.
3. If 1, 2, or 3 do not resolve the problem contact one of our factory customer service representatives for assistance and or a RGA (Return Goods Authorization) number and return the instrument for repair or replacement.

Specification

Input Voltage:	Standard Range:	8 to 28 Vdc	Select one of four input ranges.	
	Optional:	110 to 170 Vdc 85 to 165 Vac 153 to 345 Vac		
	Reverse Polarity	8 to 28 Vdc		Input Polarity Protected AC units Not Applicable
	Power Loss:	≤ 0.5 seconds		For loss of input power of less than 0.5 seconds unit will remember last state of output(s).
	Logic Reset	> 1 seconds	To Reset logic, power must be off for greater than 1 second before re-application input power	
Input Current:	DC Inputs:	400 ma. maximum	Steady State Values	
	AC Inputs:	100 ma maximum		
Set Pointers:	Quantity:	1 or 2	2 set point units only	
	Adjust:	5% to 95% of Full Scale		
	Set 1 to Set 2 Diff.:	5 % of Full Scale (Nominal)		
Output(s):	Contact(s):	1 or 2 SPDT or DPDT	@ 30 VDC @ 115/240 VAC	
	Contact Rating:	10 Amps Maximum 10 Amps maximum		
Temperature:	Operating:	-40F to +160 F / -40 C to +70 C		
Environment:	Standard:	Weather-proof Housing	NEMA 4 Class I, Groups B, C & D Class II, Groups E, F, & G	
	Optional:	Explosion-proof Housing		
Electrical Interface	Standard:	2 Ft., 18 Awg., 600V, 105 C, color coded wire leads	½" FNPT for 1 or 2 SPDT Outputs and 1 DPDT Output. ¾" FNPT for 2 DPDT Outputs.	
	Optional	Flexible metal conduit Weatherproof flexible metal conduit Extra lengths of either of above		
	Drawings:	101384 107882 108047 108158 108479 108736	8-28 VDC Input, SPDT Output 120/240 VAC Input, SPDT Output AC Input, 1 DPDT Output AC Input, 2 DPDT Output DC Input, 1 DPDT Output DC Input, 2 DPDT Output	
Materials of Construction	Weatherproof:	Cast Aluminum with "engineering plastic" bezel		
	Explosion Proof:	Cast Aluminum		

MANUFACTURER RESERVES THE RIGHT TO CHANGE SPECIFICATIONS WITHOUT PRIOR NOTICE

FIGURE 2: MOUNTING INFORMATION & DIMENSIONAL DATA

WEATHER PROOF

EXPLOSION PROOF

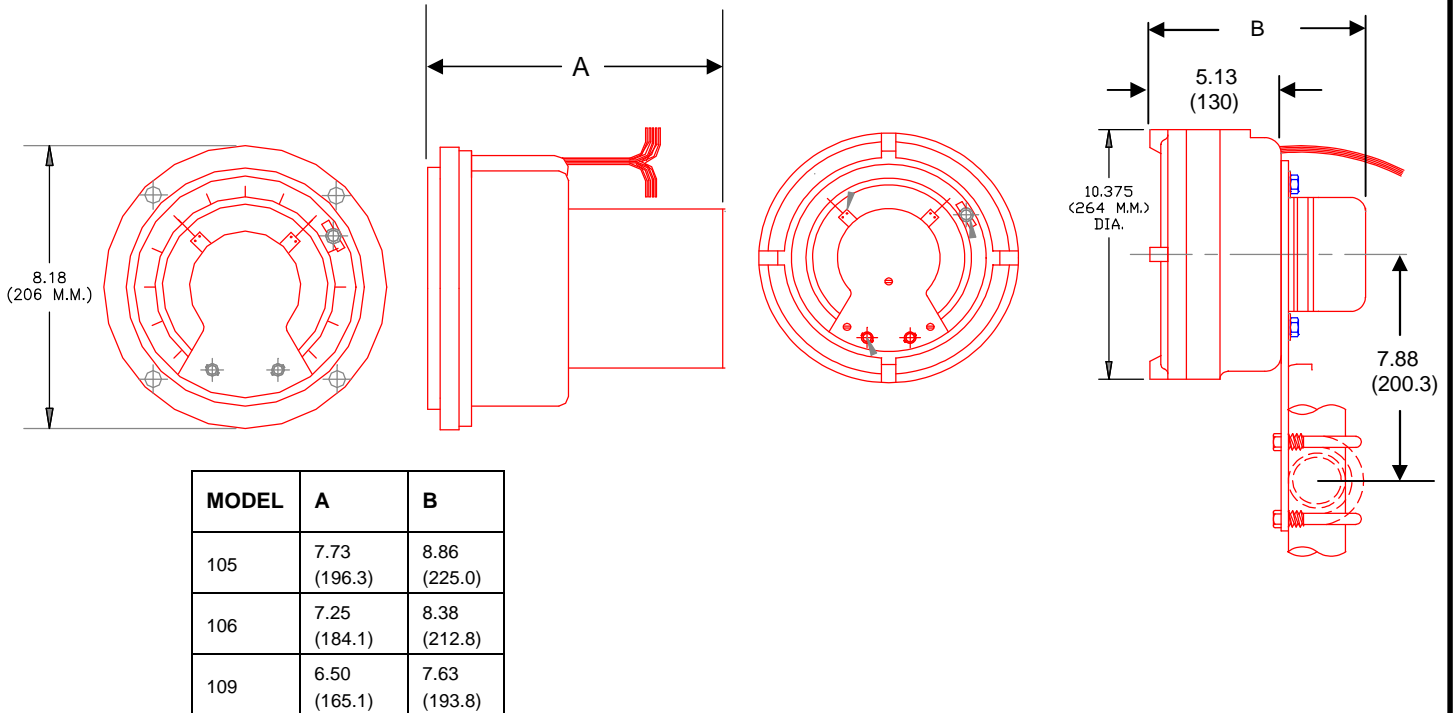

PANEL CUT-OUTS

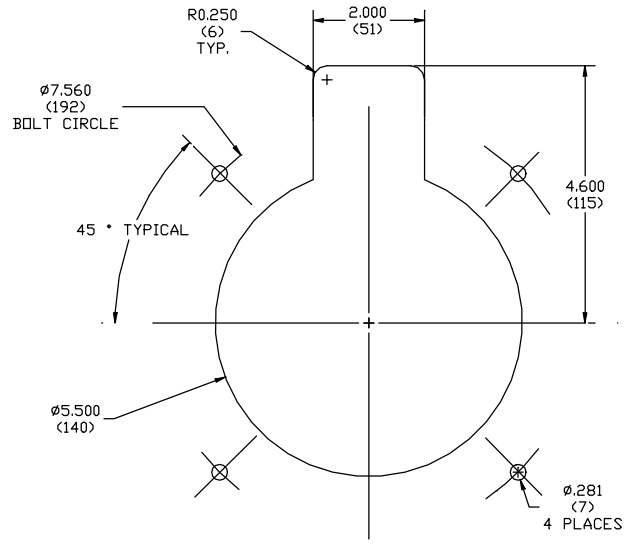
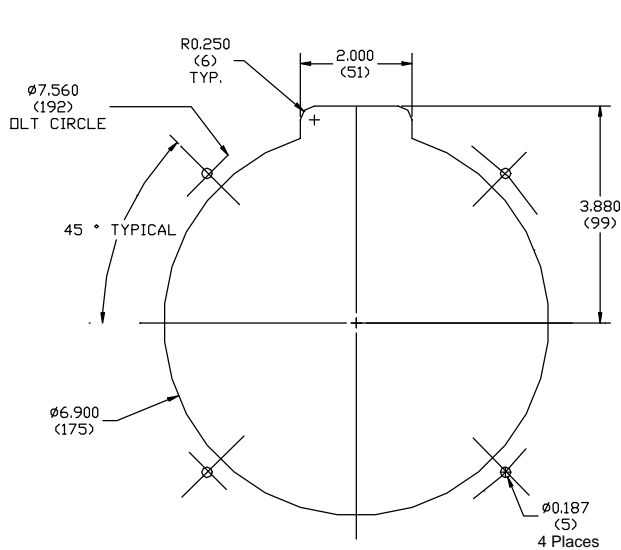

WEATHER PROOF

EXPLOSION PROOF

Mid-West®

Instrument

6500 Dobry Dr. Sterling Heights, MI 48314

(586)254-6500 FAX (586)254-6509

E-Mail: sales@midwestinstrument.com

Web Page: www.midwestinstrument.com

Data Sheet

MID-WEST[®] INSTRUMENT

Model 106 DPI "Micro-switch"



Supplied by

247able.com

Call us on +44 (0)118 916 9420 | Email info@247able.com

Mid-West[®] Instrument

Model 106 DPI "Micro-switch" Installation and Operating Instructions



INSPECTION

Before installation carefully check the Model Number on each instrument against the receiving paperwork and the intended application. Inspect for shipping damage and, if damaged, report it immediately. Verify when the unit is unpacked and in a vertical position that the pointer is on zero. **If the pointer is off zero see TROUBLE SHOOTING for instructions on zeroing the pointer.**

NOTE: **BEFORE ATTEMPTING REPAIRS,**
CONTACT YOUR LOCAL MID-WEST
REPRESENTATIVE OR OUR FACTORY.
FAILURE TO DO SO WILL VOID ANY
WARRANTY.



CAUTION:

Rapid pressurization can cause severe damage to the sensing element. Rapid pressure change (either increase or decrease) is a change in pressure occurring fast enough to drive the instrument full scale in one (1) second or less. See installation portion of this I.O.M. for guidance in how to prevent rapid pressurization.

PRODUCT DESCRIPTION

The Model 106 are all-metal differential pressure gauges capable of operating at low differential pressures for up to 6000 PSI of line pressure (Material configuration dependent).

The standard unit is equipped with one or two independently adjustable SPDT switches which can be set on decreasing or on increasing pressure. A switch adjust screw and a switch lock screw is accessible after removal of the lens and bezel (removal of 4 screws). The enclosure is weatherproof to the CSA Type 4 classification.

Interface to the snap acting micro-switch is via color coded 18 AWG flying leads and a 1/2" FNPT conduit connection. The assembly does not need power to operate.

The DPIS is also equipped with a Bi-directional Over Pressure Relief Valve (OPV). When the Differential Pressure exceeds 130% of the range the OPV equalizes the pressure between the Hi and Lo sides. Dual top and bottom connections are provided as standard. The DPIS is also equipped with a pointer zero "micro-adjust". If necessary the pointer can be re-zeroed.

INSTALLATION

All Mid-West "DPIS" alarm-controls are calibrated and tested prior to shipment and are ready for immediate installation. Use of the following installation procedures should eliminate potential damage and provide optimum trouble free operation.

- 1. CONNECTIONS** – Unit is equipped with dual ¼" FNPT connections top & bottom. Be sure that one "high" and one "low pressure connection is plumbed to the proper connection on your system. The remaining two ports should either be plugged or plumbed as bleeds. Facing the front of the gauge, the "High" port is on the right.

NOTE: It is strongly recommended that a 3-valve manifold be used in plumbing your model 106 to your system. Properly used it should insure that your instrument is not over-ranged or damaged by pressure shocks during pressurization. It will facilitate later zeroing, ranging and calibration checking. It is good practice to purge or flush the instrument loop prior to connecting the instrument.

When pressurizing the instrument have the bypass valve open. Slowly open the high side and low side isolation valves. When the unit is pressurized close the bypass valve to obtain a DP reading.

When removing the instrument open the bypass valve prior to closing the high side and low side isolation valves. Leave the bypass valve open when venting the instrument.

- 2. ELECTRICAL** – Unit is supplied with a ½" FNPT conduit hub located at the bottom of the unit. An appropriate connector must be installed before making connections to the 18" color coded flying wire leads. Wire functionality is defined as follows with zero differential pressure applied to the instrument. For 2 switch units, the left switch will be identified as the low switch and the right switch will be identified as the high switch. The color coded leads will be marked 1 (for low) and 2 (for high).

Single Switch		
Color	Function	Label
White	Common	1-Com
Black	Normally Closed	1-NC
Red	Normally Open	1-NO
Green	Earth Ground	

Double Switch			
Set	Color	Function	Label
Low (Left)	White	Common	1-Com
	Black	Normally Closed	1-NC
	Red	Normally Open	1-NO
High (Right)	White	Common	2-Com
	Black	Normally Closed	2-NC
	Red	Normally Open	2-NO
	Green	Earth Ground	

CAUTION: Follow all local Electrical Code requirements.

NOTE: Install the front cover and bezel assembly after adjusting the switch and do not leave the unit outdoors without a connector in the electrical opening or the unit may be damaged from environmental conditions.

SETPOINT ADJUSTMENT For single switch units, the switch is adjustable for decreasing differential pressures from 90% to 3% of the full scale range of the gauge and on increasing pressure from 15% to 95% of the Full Scale range. (Unless otherwise specified the decal is located for decreasing pressure set points) For 2 switch units the set point adjustment span on increasing pressure is 20% - 95%. For decreasing pressure the set point adjustment span remains the same. The adjustment screw, the set point lock screw, the switch set feedback(if provided), and the switch set flag (optional) are located inside the enclosure to protect against unauthorized adjustment. Before opening the unit to make a set point adjustment, check plant operating procedures and electrical codes. For access, remove the (4) bezel screws and the bezel assembly.

Note: For a flow dial the flow reading must be converted to differential pressure for set point verification. Set point feedback decal is not provided for gauges with a flow dial.

Setpoint Adjustment (Bezel and lens removed)

Switch Set: Decreasing Pressure: (Skip steps 1 & 2 for units that are not provided with a set point feedback decal)

1. Unlock the switch set by turning lock screw approximately ½ turn CCW. Adjust the set point adjust screw CW until the set point feedback is well below the desired switch point. Slowly turn switch adjust screw CCW until the Switch feedback is near the desired switch point.

2. With an appropriate pressure source and switch continuity checker / meter, apply pressure to the unit and verify the switch set point. If a more precise set is required perform sequence 3.
3. Apply pressure to the unit until the desired set point pressure is reached. If there is no continuity between the white and red wires, slowly reduce the set point of the switch (Turn CW) until there is continuity between the White and Red wires. If there is continuity between the white and red wires, slowly increase the set point (adjust CCW) until there is no continuity between the White and Red wires.
4. Tighten the lock mechanism (Rotate CW). Verify the switch set.
5. If ordered with a switch flag, loosen switch flag screw and manually adjust to actual switch setting. Retighten flag screw.

Note: In most cases the lock mechanism will increase the switch point 1-2% as the lock is engaged. For a more accurate set, set reduce your set pressure by 1-2% of the FSR when setting the switch.

Switch Set: Increasing Pressure: (Skip steps 1 & 2 for units that are not provided with a set point feedback decal)

1. Unlock the switch set by turning lock screw approximately ½ turn CCW. Adjust the set point adjust screw CW until the set point feedback is well above the desired switch point. Slowly turn switch adjust screw CCW until the Switch feedback is near the desired switch point.
2. With an appropriate pressure source and switch continuity checker / meter, apply pressure to the unit and verify the switch set point. If a more precise set is required perform sequence 3.
3. Apply pressure to the unit until the desired set point pressure is reached. If there is continuity between the white and red wires, increase the set point of the switch (Turn CCW) until there is no continuity between the White and Red wires. If there was no continuity between the white and red wires, slowly decrease the set point (adjust CW) until there is continuity between the White and Red wires.
4. Tighten the lock mechanism (Rotate CW). Verify the switch set.
5. If ordered with a switch flag, loosen switch flag screw and manually adjust to actual switch setting. Retighten flag screw.
6. Replace the bezel assembly and screws.

Note: In most cases the lock mechanism will increase the switch point 1-2% as the lock is engaged. For a more accurate set, set reduce your

set pressure by 1-2% of the FSR when setting the switch.

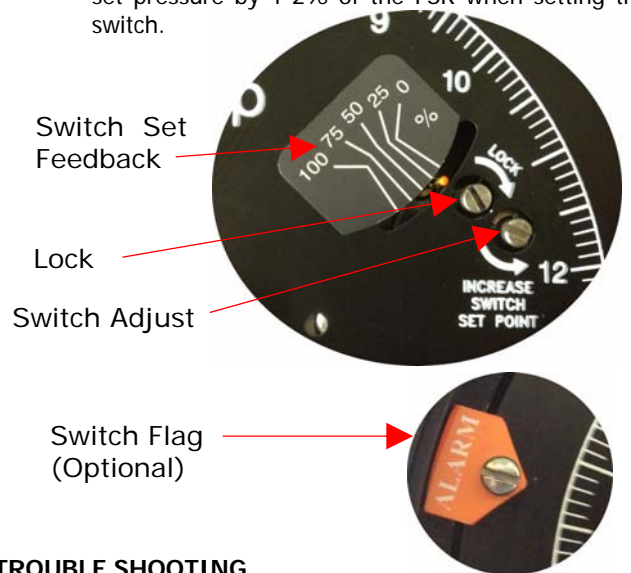

TROUBLE SHOOTING

1. Gauge does not indicate differential.

- A. Check for proper hook up, high to high and low to low.
- B. Make certain that block valves are open and, if using a 3-valve manifold, that the equalizer (balance) valve is closed.
- C. If A and B check out correctly, loosen or disconnect the high pressure line to determine if there is pressure to the instrument.
- D. If there is pressure to the instrument, check to determine that there is a differential across the unit being monitored. If there is, contact the factory for assistance and for an "RGA" (returned goods authorization) number to return the instrument for repair or replacement.

2. Indicating pointer off zero. (With block valves closed, equalizer valve open, or no system differential.)

- A. Tap gauge **lightly**.
- B. Make certain block valves are closed and equalizer valve is open.
- C. If A & B do not correct the "off zero" condition, remove the bezel and lens assembly by removing the (4) bezel screws. Grasp the pointer hub between the thumb and forefinger. Using a straight blade screw driver adjust the screw on the pointer clockwise to adjust the pointer upscale or counter clockwise to adjust the pointer downscale. Tap the gauge lightly to confirm the pointer is on zero. Reinstall the bezel and lens assembly.

RECALIBRATION AND/OR REPAIR

1. If recalibration or repair is required, secure an "RGA" (returned goods authorization) number from Mid-West Instrument and return the instrument to the factory.
2. If (1) is not practical, we recommend you discuss your problem with one of our customer service representatives and request a "technical service" manual. Please have both the model and serial numbers available before calling.

Specification

ELECTRICAL



® Industrial Control Equipment

Input Voltage: None required

Set Pointers:	Quantity:	1 or 2	
	Adjust:	3% to 90 % of Full Scale	Set on Decreasing
		15% to 95% of Full Scale (Single Sw)	Set on Increasing
		20% to 95% of Full Scale (Double Sw)	Set on Increasing

Output(s):	Contact(s):	1 or 2 SPDT	
	Contact Rating:	4 Amps Maximum	@ 30 VDC
		3 Amps maximum	@ 240 VAC
		5 Amps	@ 120 VAC

Temperature: Operating: -20F to +185 F

Environment: Standard: Weather-proof Housing CSA TYPE 4

Electrical Interface: Standard: 18" ., 18 Awg., 600V, 105 C, ½" FNPT color coded wire leads

Gauge Accuracy:* (Decreasing Pressure) 2% For all Single Switch Including effects of the switch, Double switch for ranges 200" H2O and above.

4% Double Switch units including effects of the switch. For ranges 80" – 199" H2O only.

Switch Repeatability:* 2% Max. for all single switch units & all double switch units ranges 200" H2O and above.

4% Double Switch units for ranges 80" – 199" H2O only.

* Accuracies and repeatability values for 2 switch units are based upon one switch set low (approx 25% FSR & one switch set High approx. 75% FSR.).

MECHANICAL:

Material: Body; Aluminum, Carbon Steel, Stainless Steel, or Brass (See IM 105-106/xx Part Numbering System)
Moving Parts: 316/L SS
Bezel, Housing: Anodized Al

Ports: ¼" FNPT Top & Bottom

Working Pressure: 6000 PSI (Material dependent) See IM 105-106/xx Part Numbering System
Proof Pressure: 2X working pressure or 10,000 PSI whichever is lower at ambient temperature

Dial: Black Aluminum with White Lettering

Pointer: White Aluminum, micro adjust

Environmental: CSA Type 4

Standards: C22.1 No.14-10 ; C22.2 No 94-M91 Type 4 enclosure

MANUFACTURER RESERVES THE RIGHT TO CHANGE SPECIFICATIONS WITHOUT PRIOR NOTICE

FIGURE 2: DIMENSIONAL DATA

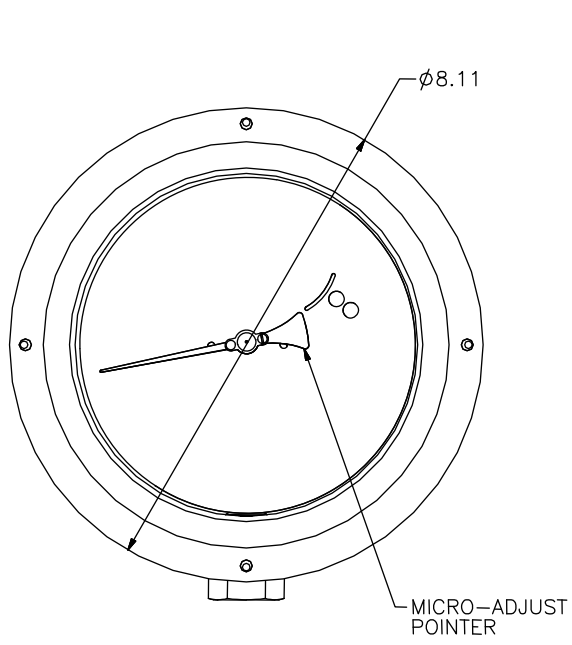

WEATHERPROOF

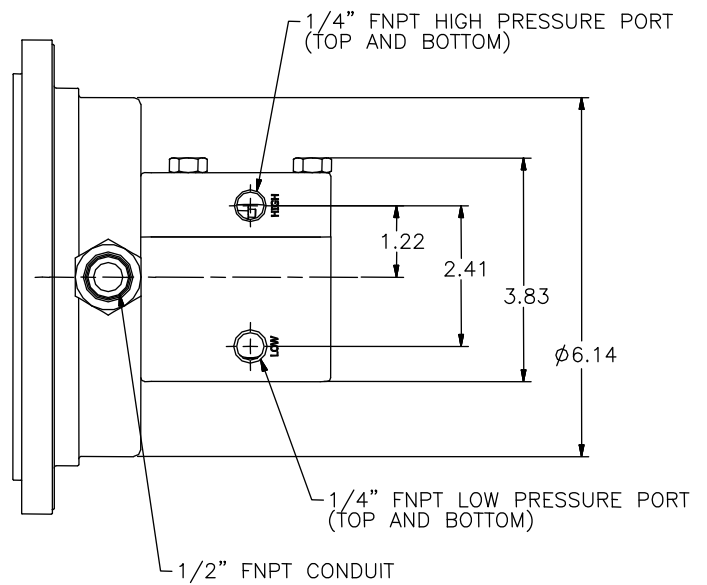
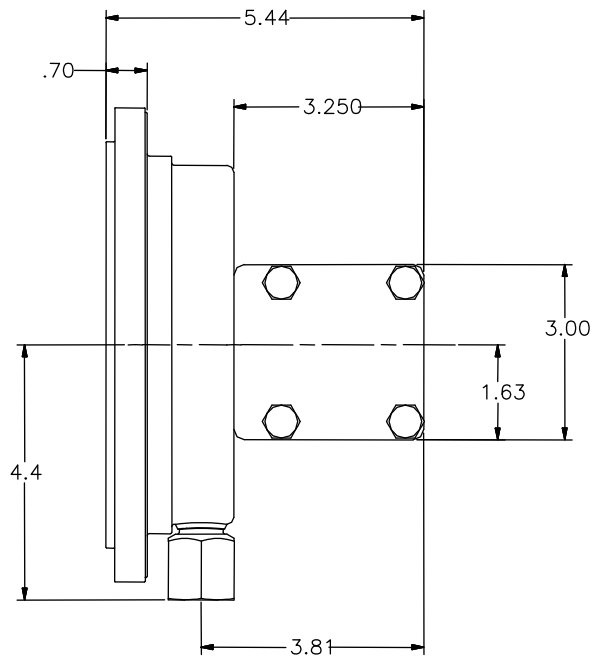

Mid-West®

Instrument

6500 Dobry Dr. Sterling Heights, MI 48314

(586)254-6500 FAX (586)254-6509

E-Mail: sales@midwestinstrument.com

Web Page: www.midwestinstrument.com