

Installation & Maintenance Instructions

MID-WEST INSTRUMENT

Model 121



Supplied by

247cable.com

Call us on +44 (0)118 916 9420 | Email info@247able.com

Electrical Installation and Operating Instructions - Model 121

1. Safety



Before installing, check the Model Number and verify compatibility to the process media and temperature in contact with the wetted parts. Incompatible media and / or operation at temperature extremes can cause premature degradation of materials which could result in safety risk to personnel.

Verify the selected pressure range (differential pressure and working pressure) and the switch ratings are within specification for your application.

Warning! *Perform all electrical adjustments with power removed.*

The Model 121 product utilizes a piston design which inherently has a small amount of leakage from high process connection to low process (15 SCFH air max at 100 PSID) connection. Do not use this product in an application with the low side process connection left open to atmosphere.

This product utilizes a magnet as part of the sensing element. Magnetic particles in the process can cause the piston to stick or become wedged in the bore.



Warning! *Remaining media may result in a risk to personnel, environment etc. Use sufficient precautionary measures when removing and transporting the product.*



Warning! *If installing product within another enclosure that is pressure tight, please verify all process connection are leak tight. Leakage within a pressure tight (ie NEMA 4X) enclosure could cause a pressure buildup within the enclosure and cause a burst scenario.*

1.1 Intended use: The indicating / non-indicating differential pressure switches or transmitter are used for monitoring differential pressures in industrial applications.

The manufacturer shall not be liable for any claims if the product is used in applications contrary to the intended use.

1.2 Personnel: Personnel installing and putting this instrumentation into service shall be suitably trained and qualified in accordance with local codes, practices and regulations.



1.3 Labeling / Marking: The following Electrical Configurations bear this mark and comply with the relevant European Directives identified on the declaration of conformity: A, B, E, F, T, W



The following electrical configurations may bear 1 or both of these third party listing agency marks for product evaluated to both US and Canadian Standards: E, F, W

Electrical Installation and Operating Instructions - Model 121

2.0 General Specifications

Non-electrical

Parameter	Limits(Std)	Limits (Hazardous Locations)
Working Pressure(PSI)	3000 (AL) Non Haz-Loc 6000 (SS) Non Haz-Loc	3000 (AL) 5000 (SS)
Proof Pressure(PSI)	12,000 (AL, SS) 20,000(SS)	
Temperature	-40° to 200° F (Switches) -20° F to 150° F (Transmitter)	
Differential Pressure Range (PSID)	0-5 to 0 to 110	
Indicator Accuracy ASME B40.100	2%	
DP Over-Range	+/- Proof pressure	

Electrical

Parameter	Switch Specification	
	SPST	SPDT
Option:	E ,F,G	A
*Power	60 W	3W
Max. Current	3.0 Amps	0.25 Amps
Max. Voltage VAC/VDC	240	125
**Setting (%F.S.)	20 to 95	15 to 95
Hysterisis (Max/Nom)	18% / 10% (F.S.)	12% / 8% (F.S.)
Repeatability	1% F.S.	1% F.S.

* Product of the switching voltage and current shall not exceed the power rating of the device.

** Except where otherwise noted

Transmitter

Transmitter Specifications: (Calibrated on Increasing pressure)					Comments:
Operating Temperature (Max.)	-20° F - 150° F				
ELECTRICAL:					
	Min	Typ	Max		
Transmitter Accuracy (FSR)			2%	Upper 80% of Full Scale Range	
Supply Voltage (3) (Vdc)	8		28	Pin 3 Reverse Polarity Protected	
Output Current (ma)					
Zero Floating (2)	4.0 – 20.1 ma	4.0 – 21.0	4.0 – 22.0	Pin 2	
Zeroed (1 connected to 2)		8			
Voltage (Pin 2 to 1)	4.8		6.3		
Zero Time (seconds)	2				
Max Loop Resistance (ohms)			1000		
Max Loop Resistance Formula	$((V_s - 8) * 1000) / 20$				
INTERFACE:					
Electrical:					
Connections:	4 Position Terminal Strip; ½" NPT Conduit 1= Rtn, 2= Zero, 3= 8-28 Vdc In 4= Chassis				22 Awg – 16Awg Wire
Environmental Rating:	NEMA 4X				
Certifications:	CSA (Canadian & US Standards; Division 2 Locations)				

Electrical Installation and Operating Instructions - Model 121



3.0 Product Description:

Switch Differential pressure is sensed by the movement of a floating piston magnet against a calibrated spring. The magnetically coupled gauge pointer located outside the pressure housing follows the movement of the piston magnet and indicates differential pressure on the dial. The switches are also magnetically operated and are located outside of the pressure housing. The switches are mechanically adjustable allowing the customer to set the switch within a defined adjustment span of the range of the instrument.

This instrument is mainly intended for gas / air / oil applications.

Transmitter The Model 121 indicating / non-indicating differential pressure transmitter is a 2 wire loop powered microprocessor based 4-20 ma transmitter. The magnetic angle sensor & electronics senses the angle (relative to the transmitter sensor) of the magnet which moves linearly in the bore. Each transmitter is individually calibrated to the gauge using an 11 point calibration linearization technique. This method results in a <2% full scale accuracy for the upper 80% of the range.



4.0 Installation:

Tools Required: Phillips Screwdriver, Adjustable or 11/16" wrench (end connected process), small slotted screwdriver.

Mechanical Connections: 1/4" FNPT are provided standard, however check your paperwork to confirm the connections ordered. There are 2 connections identified on the gauge body as "Hi" and "Lo" for High pressure and Low pressure respectively. Be sure these are plumbed properly in your system. Improper connection will not damage the instrument, but it will not function properly.



Do not allow gauge fittings to rotate when making process connections. Calibration and / or pressure rating of the product may be compromised.

For end connected or gauges supplied with adapter fittings use two wrenches when making connections. Use one wrench to hold the pressure port fitting on the gauge and the other to tighten the process pipe of tube fitting.

Instrument Location: On liquid service the instrument should be mounted below the process connections to facilitate self-bleeding. On gas service it should be located above the process connections to promote self-draining. If the process contains particulates, a pigtail loop or drop leg (manometer "U-tube" configuration) in the tubing will minimize the possibility of it migrating into the instrument.

Temperature Limitations: For process temperatures higher than the rated temperature of the dp gauge / switch, use process tubing to reduce the temperature. A general "rule of thumb" is that for horizontal tubing runs the temp drop is 100° F/ ft. Another option is to use "cooling towers" to protect the instrument.

Verify the selected elastomer option is appropriate for your operating temperature.

Wall / Pipe / Panel Mounting: Not all combination of options can be wall, pipe, or panel mounted. If your unit is supplied with a wall or panel mount, possible configurations are shown below:

Wall Mount Configurations: (Not available for back connections) 4 1/2" Dial configuration shown. Bracket is the same for the 2 1/2" Dial

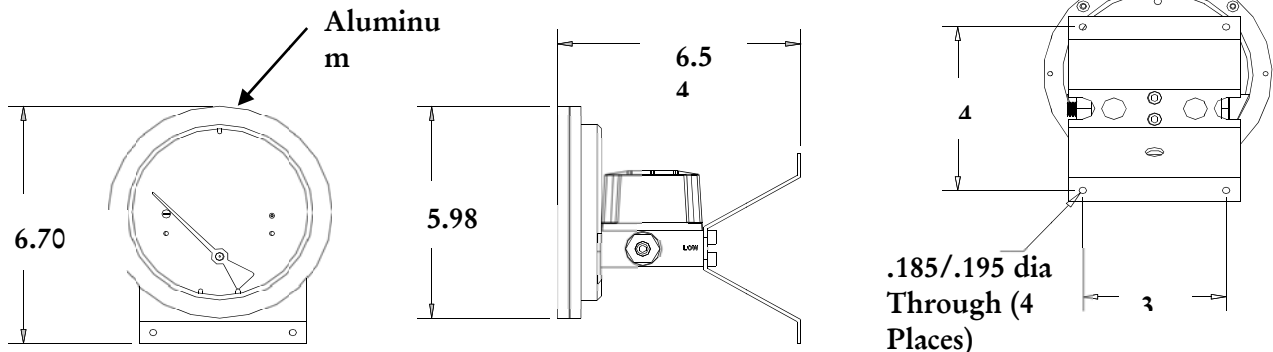

Electrical Installation and Operating Instructions - Model 121

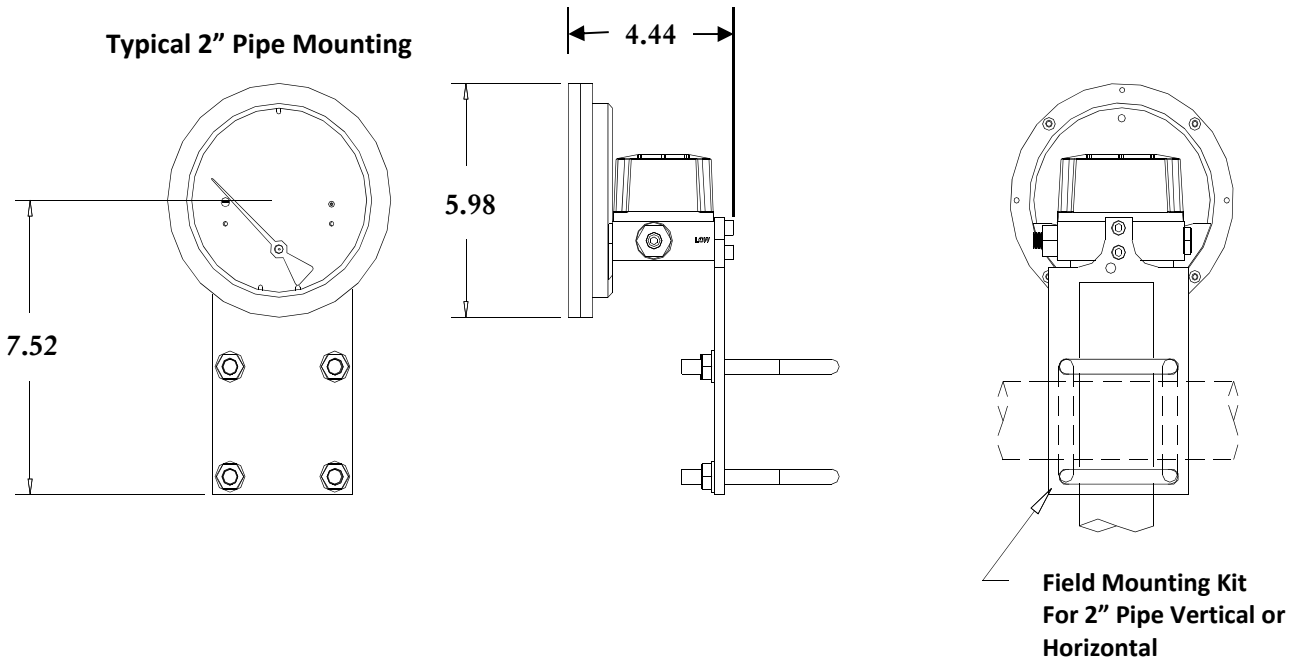

Panel Mount: Gauges with 2 ½" dials can only be mounted through the rear of the panel. Make the proper panel cutout as shown below. Remove the (4) bezel screws and insert the gauge front through the rear of the panel. Reinstall the bezel screws through the front of the panel and into the gauge bezel. Tighten screws securely in an alternating diagonal pattern.

Gauges with 3 ½" dials should be mounted from the front of the panel. Contact the factory for mounting and dimensional information.

Gauges with 4 ½" dials should be mounted from the front of the panel. Make the cutout as indicated below. Insert the (4) panel studs, finger tight, into the metal inserts located in the rear of the bezel. Insert the gauge through the panel, aligning the panel mounting studs with the holes in the panel. Install the (4) 8-32 nuts onto the studs and tighten securely.

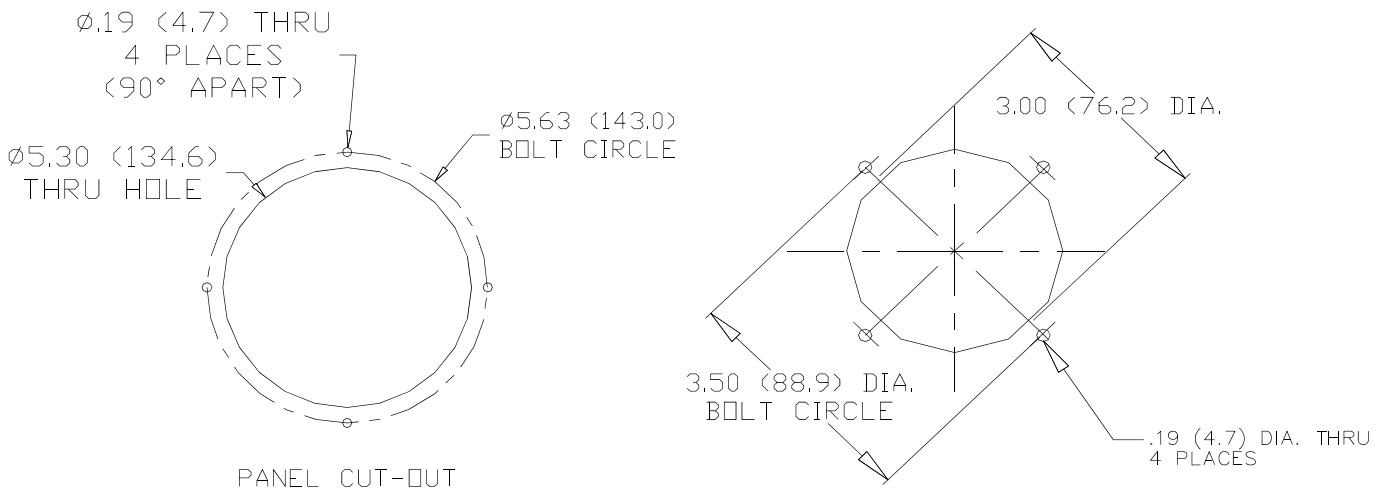

4 ½" Dial Panel Cut-out

2 ½" Dial Panel Cut-out

Electrical Installation and Operating Instructions - Model 121

Electrical:



Warning: *Electrical connections should be performed by qualified personnel and meet the representative country's national electrical code.*

Warning: *Failure to connect to the protective conductor terminal may result in a shock hazard.*

Warning: *Perform all switch adjustments with power removed. Use an ohmmeter or equivalent to monitor contact operation.*

Caution: *Preference should be given to setting the switch prior to installation. It is also recommended to perform adjustments using a non-magnetic Phillips screwdriver.*

General: All switch types are field adjustable. The defined range of the adjustment is specified in the table above. All switches come with a decal to identify adjustment direction to increase the set point.

Switch Set Point Adjustment



Do not use excessive force when rotating the adjustment screw as the adjustment mechanism may be damaged. Also note the location of the screw adjust (See Figure 4.) Do not mistake it for the calibration adjust for the gauge.

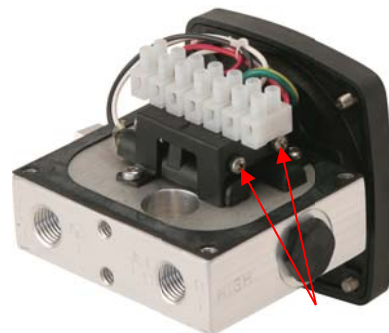

Switch Adjusts

Note: *Switches can be set below the defined minimum set point however, the switch may not remain activated at maximum PSID. If the unit is set below the defined minimum set point, the customer should verify that the switch remains activated from the set point to over range of the gauge.*

The switch may be set using the indicating dial as a reference (units with a dial) or by using a reference pressure gauge.

For setting on increasing pressure increase your pressure to the desired set point. Increase the switch set point above the desired switch set (switch deactivated). Slowly decrease the switch set point until the contact activates.

Contact Protection: Provide standard protection techniques for the switch contacts for capacitive and inductive loads. Use current limiting techniques near the switch to protect the contacts due to high inrush (i.e.; in line resistor or inductor) for long cable interfaces. Provide clamping devices at or near inductive loads (i.e.; relay).



Maximum wire length between the 3W switch and its load should not exceed 70 – 100 Feet for 120 VAC applications. We recommend that you use the SPST switch or use a current limiting resistor wired in series and located near the switch. Contact the factory for assistance regarding this condition. (For hazardous Locations the resistor option is not allowed)

Connections: The reed switch(es) are located inside the enclosure, on the top of the pressure housing, and are connected to a 7 position terminal strip. A ½" FNPT conduit interface is provided through the bottom of the gauge body.

To access the terminal strip remove the switch enclosure cover by removing the (4) screws with a phillips screwdriver.. Insert wires through an appropriate (not supplied) weatherproof connector into the enclosure and connect to the terminal strip per the terminal strip diagram shown below or on the underside of the switch enclosure cover. The center connection is for connection of a protective conductor and is connected to the body of the pressure gauge.

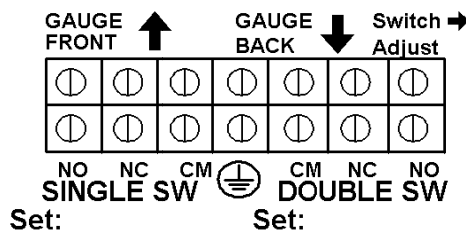

The terminal strip will accept wires in the range of 22 Awg - 16 Awg.. Reinstall the cover, gasket, and (4) screws. (Fig. 3) after connection of field wiring.

Electrical Installation and Operating Instructions - Model 121

Wiring for the SPST switches is connected between NO and CM connections on the terminal strip. Normally closed switches are generally not available. Pre-set switches will have their set points identified on the label.

Electrical Configurations A, B, E, F

Electrical configurations A, B, E, & F can be used in Pollution degree 3 Industrial type areas. These configurations are rated NEMA 4X IP 65.



Note: These Configuration have a 1/2" FNPT conduit interface. The safety evaluation and the NEMA ratings for these configurations was performed with this access sealed.

Electrical Configurations E & F:



The E & F Electrical Configuration are 3RD party certified for **Class I, Division II, Groups A, B, C, & D, Class II, Groups F & G** hazardous environments. The CSA mark identifies the product has been tested to the applicable **US standards and Canadian standards.**



Warning! Please note the pressure ratings on the Hazardous Locations Tag.

Ind. Cont. Eq. **Mid-West**
AP Switch Model# Instrument
121SA-10-F(EA)
Working Pressure: 5000
Ratings (Resistive) For Use In
3W MAX
0.25 A MAX
120 VAC/VDC MAX

Hazardous Locations:
Class I, Div. 2, Groups A,B,C,D
Class II, Div. 2, Groups F & G

Electrical Configurations T or W: (Transmitter Option)

Intended use: The Model 121 Transmitter is intended for use in General Purpose Locations (T electrical configuration) or Division 2 hazardous locations (W electrical configuration). In both cases the enclosure carries a NEMA 4X IP65 environmental rating.

Description: The transmitter assembly if **CE** marked is also compliant with EMC Directive 2004/108/EC. The transmitter has a factory programmed low-pass filter. The filter is set to approximately 1 second. This can be increased or decreased upon customer request at the time of order.

Note: The transmitter circuitry senses the position of a magnet. Any magnetic object located near the gauge may affect transmitter accuracy.



The transmitter if necessary can be zeroed by jumpering pin 2 to Gnd pin 1 momentarily for 2 seconds (with the unit powered). In most cases this will never be necessary as the transmitter is programmed to generate a 4ma output for the first 2% of the FSR.



Warning: If zeroing in the Hazardous Location environment use a switch approved for that location.



Caution: Do not zero the transmitter with pressure applied. Otherwise your product will have a negative offset equivalent to the pressure when the zero was activated.



Caution: Do not attempt to reposition the transmitter assembly within the enclosure. This voids the warranty and will "knock" the unit out of calibration. Disassembly and re-assembly of any internal process parts will also require the unit to be re-calibrated. Calibration must be performed at the factory

Connections: The weather-proof enclosure comes standard with a 1/2" FNPT conduit interface. The internal 4 position terminal strip accepts wire sizes 22 AWG – 16 AWG.

To access the 4 position terminal strip, remove the 4 cover screws from the enclosure. Connect loop power between the connections labeled 8-28 Vdc and Return (see Figure below). Connect the protective conductor wire to the terminal identified with the  symbol. See the Interface schematic below. Please note that the loop power sensing device can also be located in the ground leg.

Electrical Installation and Operating Instructions - Model 121



Warning: When wiring to the terminal strip, make sure all wire strands are contained within the terminal connection.

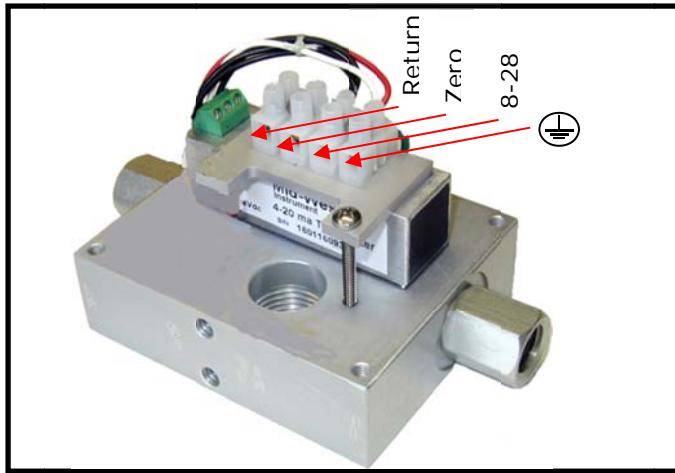

The maximum loop resistance is 1000 ohms (@ 28Vdc Input). Use the following formula to determine the maximum loop resistance at other input voltages: $((V_s - 8) * 1000) / 20$

Electrical Configuration W (Transmitter):

The **W** Electrical Configuration is 3RD party certified for **Class I, Division II, Groups A, B, C, & D, Class II, Groups F & G** hazardous environments. The CSA mark identifies the product has been tested to the applicable **US standards and Canadian standards.**

Interface Schematic

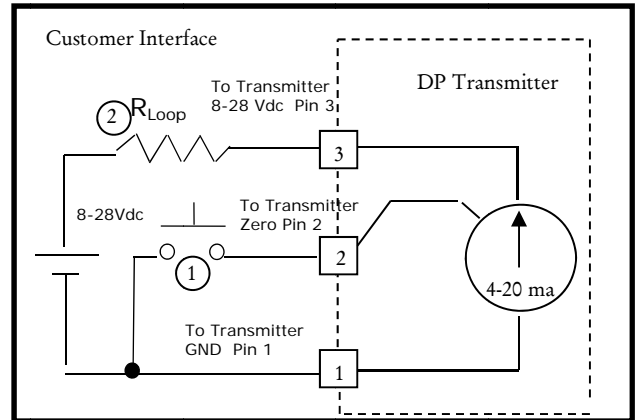

- ① Optional remote zero (customer supplied)
- ② Loop Resistor can be located in the ground leg



Warning: Please note the pressure ratings on the Hazardous Locations Tag.

Ind. Cont. Eq. AP Switch Model#	Mid-West Instrument
121AA-10-O(WT)	
Working Pressure: 3000 PSIG	
Ratings (Resistive) For Use In	
Transmitter 4-20 mA output 8-28 Vdc Input	Hazardous Locations: Class I, Div. 2, Groups A,B,C,D Class II, Div. 2, Groups F & G

5.0 Dimensions:

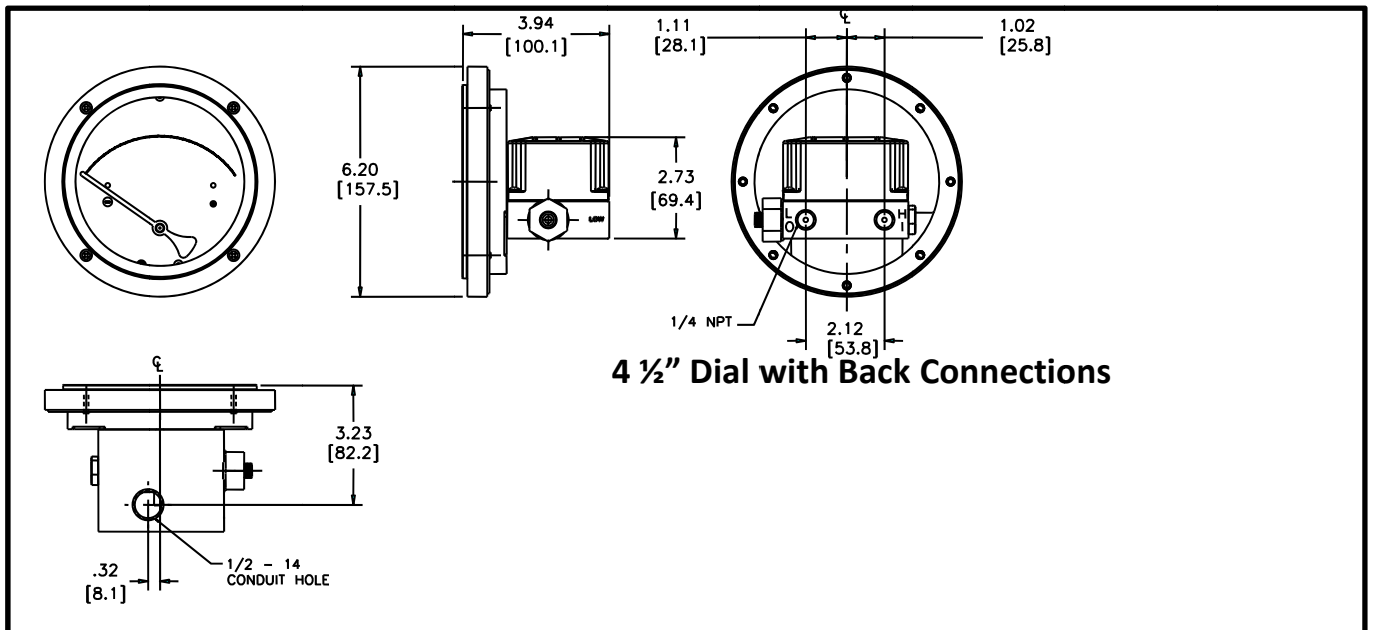

Electrical Installation and Operating Instructions - Model 121

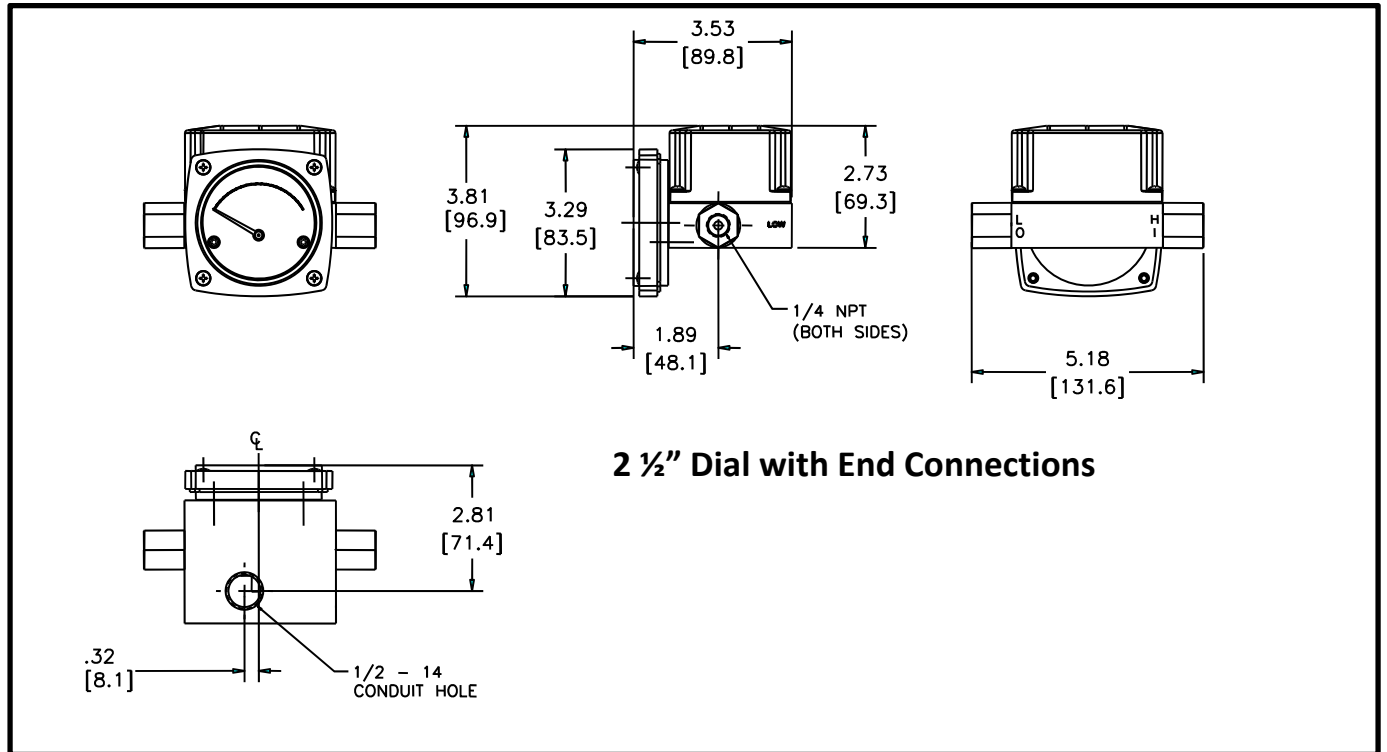

6.0 Troubleshooting

A. Gauge accuracy and set point problems:

- i. Verify your process connections are plumbed properly.
- ii. Verify gauge is not in an electromagnetic / magnetic environment. i.e.; close proximity to high current power lines
- iii. Verify the pointer has fluid movement as pressure increases. Jumpy movement or no movement may indicate a stuck piston.
- iv. All others contact the factory for assistance.

B Switch doesn't function

- i. Make sure that the switch load does not exceed the specified wattage rating of the switch. (steady-state and transient). Contact factory for assistance for excessive loads, otherwise proceed to the next step.
- ii. Perform a continuity check of the switch contacts by trying to actuate the switch using an external magnet. An operational switch usually indicates a problem with the gauge. If not operational proceed to the next step.
- iii. Verify the reed switch wires are connected to the terminal strip (NEMA 4X enclosure only). Contact the factory for assistance if the switch is connected and/or request an "RGA" number.

C. Transmitter doesn't function

- i. Make sure you have supplied power (proper voltage) to the unit.
- ii. Check that you are wiring to the correct Interface terminals.
- iii. Check the transmitter interfaces to the terminal board for loose connections.
- iv. Make sure that the loop resistance does not exceed the specified rating.
- v. Make sure you did not zero the unit with pressure applied. Try a re-zero at 0 pressure.

Electrical Installation and Operating Instructions - Model 121

7.0 Misc:

CE Marking Statements:

Low Voltage Directive: The Electrical Configurations A, B, E, F, of this product are CE marked in compliance with the Low Voltage Directive to EN-61010-1. Electrical configurations T and W fall outside the scope of the directive.

ATEX Directive 94/9/EC: Model 121 product has not been evaluated to the ATEX directive.

Pressure Equipment Directive : The Pressure Equipment Directive has been determined to be **non-applicable for CE marking for Group 1 applications below 200 bar or Group 2 applications below 1000 bar..** These products are manufactured in accordance with article 3, paragraph 3 of the directive, "sound engineering practice". They fall below category I for non-hazardous gases, hazardous liquids, & non-hazardous liquids. This product also falls below category I for hazardous gases at or below 200 bar.

For Group 1 applications above 200bar, this product has not been evaluated to meet the essential safety requirements of Annex I of the Pressure Equipment Directive. Use of this product in an EU member state shall be limited to less than 200 bar for Group 1 applications.

EMC Directive(2004/108/EC): Optionally, transmitters (Electrical Configurations T & W) may be CE marked for compliance with the EMC Directive. Presently the product is being re-evaluated for compliance with EMC Directive 2014/30/EU which superseded 2004/108/EC. The transmitter design has been evaluated to and passed the following "EN" Standards as they relate to the EMC directive.

EN 61326:2013 Environment Industrial, Electrical Equipment for measurement, Control and Laboratory use,

EMC requirements from which:

EN55011:2009 + A1:2010	Emission, Class B
EN61000-4-2:2009	Electrostatic discharge (ESD) immunity
EN61000-4-3:2006 +A1:2008 +A2:2010	Radiated EM field immunity
ENV50204:1995	Radiated EM field immunity from digital telephones (GSM)
EN61000-4-4:2004 +A1:2010	Electrical fast transient (EFT) immunity
EN61000-4-5:2006	Surge transient immunity
EN61000-4-6:2009	RF conducted immunity
EN61000-4-8:2010	Power Frequency magnetic field immunity

For all other configurations the EMC Directive is non-applicable.

ROHS Directive:

The electrical Configurations A, B, E, F of this product are CE marked in compliance with the RoHs directive 2011/65/EU (RoHs2). Electrical Configurations T & W will be CE marked for compliance with RoHS2 when the product is marked for compliance with the EMC Directive.

Warning: *The suitability of the application and installation of this differential pressure switch / transmitter is the responsibility of the end user. The applicable certifications, listings apply to the differential pressure switch / transmitter only*

STANDARDS: All Model 121 Series differential pressure gauges either conform to and/or are designed to the requirements of the following standards:

ASME B1.20.1	NACE MR0175
ASME B40.1	NEMA Std. 250
EN-61010-1	UL Std. No. 50, 508, & 1604
EN 50581	CSA-C22.2 No. 14, 25, & 213